

ASSP Communication Control

CMOS

FAST-20 SCSI Protocol Controller

MB86606

■ DESCRIPTION

The MB86606 is an intelligent SCSI protocol controller (SPC) conforming to the ANSI (FAST-20) standard and integrating a PCI local bus interface function. The specification of SCSI controller block is based on the MB86605's one which is a Wide SCSI protocol controller, but the device functions/features to achieve the FAST-20 data transfer rate of maximum 40 Mbyte/sec at 16-bit FAST-20 SCSI, such as the size of internal data register FIFO, are larged on the MB86606. As for the SCSI bus pins, a totem pole type single-ended driver/receiver is incorporated in the device so that it can drive the SCSI bus directly. Furthermore, the MB86606 is capable of connecting the external differential type driver/receiver.

The SCSI bus sequence is controlled by commands issued via the system interface. So, it supports sequential commands that perform the phase-to-phase sequences to reduce the overhead of system's sequence operations.

As another key feature to reduce the system overhead, the device has a 2 Kbytes user program memory to store the user program with the commands. Due to this, all the SCSI bus sequences including the data transfer can be performed automatically.

As the system interface block, it incorporates a 32-bit PCI local bus interface that easily realizes the SCSI interface on the motherboards of PCI bus based PCs and WSs, in addition to a 16-bit separate MPU and DMA buses. For the on-chip PCI bus interface, the MB86606 also incorporates a 32-bit DMA controller that is capable of supporting the scatter-gather function so that the data transfers can be controlled by both user program and the host system.

The device is fabricated by the advanced CMOS process and is housed in an 144-pin plastic Shrink Quad Flat Package (Suffix: -PMT).

■ PACKAGE

144 pin, Plastic SQFP

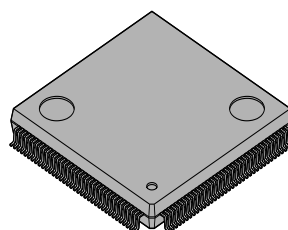

(FPT-144P-M05)

(Continued)

System Interface Block:

- Separate MPU and DMA buses called 16-bit Bus Mode
Directly connectable to 68-series or 80-series MPU
Two transfer modes (Program transfer and DMA transfer (slave mode))
- PCI Bus Interface Mode
Directly connectable to the 32-bit PCI local bus.
On-chip 32-bit DMAC for PCI bus master
Supports the PERR&SERR function
Supports the INTA# Interrupt Signals
Max. 64 bytes burst transfer
PCI system clock: Max. 33 MHz
- Data Bus Parity and Address Bus Parity (only for PCI bus interface mode) generation/check function

Others

- Compact 144-Pin Plastic Shrink Quad Flat Package (SQFP, Package Suffix: -PMT)
- Pin compatible with MB86605
- Supply Voltage: 5V \pm 5%

MB86606

■ PIN ASSIGNMENT

- 16-Bit Bus Mode

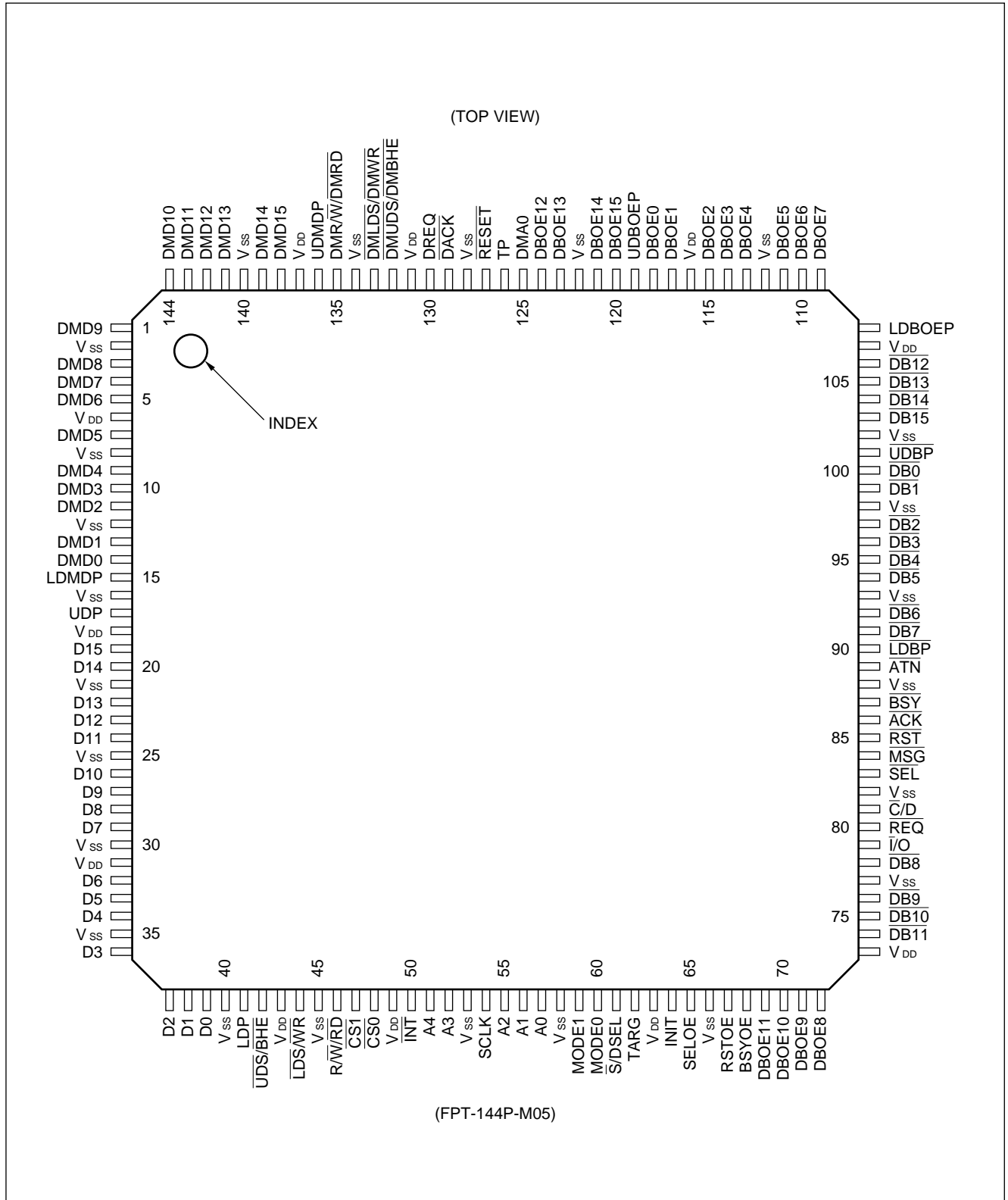

MB86606

• PCI Bus Interface Mode

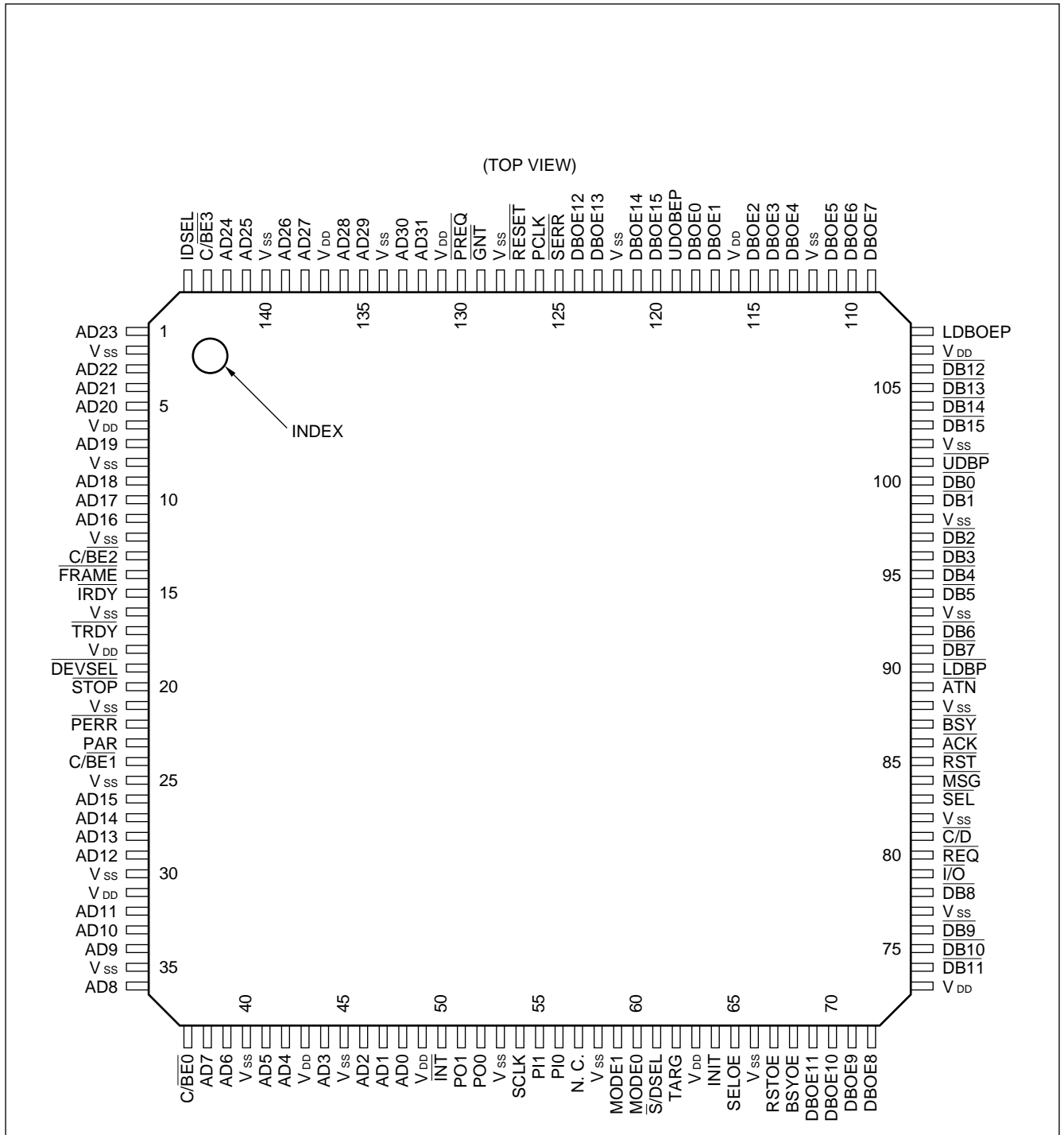

MB86606

■ PIN LIST

Pin no.	16-bit bus mode				PCI bus I/F mode		Pin no.	16-bit bus mode				PCI bus I/F mode		
	Mode 0 (68 I/F)		Mode 1 (80 I/F)		Mode 3 (PCI I/F)			Mode 0 (68 I/F)		Mode 1 (80 I/F)		Mode 3 (PCI I/F)		
	I/O	Pin name	I/O	Pin name	I/O	Pin name		I/O	Pin name	I/O	Pin name	I/O	Pin name	
1	I/O	DMD9			I/O	AD23	31	—	V _{DD}					
2	—	V _{SS}						32	I/O	D6		I/O	AD11	
3	I/O	DMD8			I/O	AD22	33	I/O	D5		I/O	AD10		
4	I/O	DMD7			I/O	AD21	34	I/O	D4		I/O	AD9		
5	I/O	DMD6			I/O	AD20	35	—	V _{SS}					
6	—	V _{DD}						36	I/O	D3		I/O	AD8	
7	I/O	DMD5			I/O	AD19	37	I/O	D2		I/O	C/BE ₀		
8	—	V _{SS}						38	I/O	D1		I/O	AD7	
9	I/O	DMD4			I/O	AD18	39	I/O	D0		I/O	AD6		
10	I/O	DMD3			I/O	AD17	40	—	V _{SS}					
11	I/O	DMD2			I/O	AD16	41	I/O	LDP		I/O	AD5		
12	—	V _{SS}						42	I	UDS	I	BHE	I/O	AD4
13	I/O	DMD1			I/O	C/BE ₂	43	—	V _{DD}					
14	I/O	DMD0			I/O	FRAME	44	I	LDS	I	WR	I/O	AD3	
15	I/O	LDMDP			I/O	IRDY	45	—	V _{SS}					
16	—	V _{SS}						46	I	R/W	I	RD	I/O	AD2
17	I/O	UDP			I/O	TRDY	47	I	CS ₁		I/O	AD1		
18	—	V _{DD}						48	I	CS ₀		I/O	AD0	
19	I/O	D15			I/O	DEVSEL	49	—	V _{DD}					
20	I/O	D14			I/O	STOP	50	^{0/} _{OD}	INT					
21	—	V _{SS}						51	I	A4		O	PO1	
22	I/O	D13			I/O	PERR	52	I	A3		O	PO0		
23	I/O	D12			I/O	PAR	53	—	V _{SS}					
24	I/O	D11			I/O	C/BE ₁	54	I	SCLK					
25	—	V _{SS}						55	IU	A2		IU	PI1	
26	I/O	D10			I/O	AD15	56	IU	A1		IU	PI0		
27	I/O	D9			I/O	AD14	57	IU	A0		IU	N.C.		
28	I/O	D8			I/O	AD13	58	—	V _{SS}					
29	I/O	D7			I/O	AD12	59	I	MODE1					
30	—	V _{SS}						60	I	MODE2				

(Continued)

(Continued)

Pin no.	16-bit bus mode				PCI bus I/F mode		Pin no.	16-bit bus mode				PCI bus I/F mode	
	Mode 0 (68 I/F)		Mode 1 (80 I/F)		Mode 3 (PCI I/F)			Mode 0 (68 I/F)		Mode 1 (80 I/F)		Mode 3 (PCI I/F)	
	I/O	Pin name	I/O	Pin name	I/O	Pin name		I/O	Pin name	I/O	Pin name	I/O	Pin name
61	I	$\overline{S}/DSEL$					91	I/O	$\overline{DB7}$				
62	O	TARG					92	I/O	$\overline{DB6}$				
63	—	V_{DD}					93	—	V_{SS}				
64	O	INIT					94	I/O	$\overline{DB5}$				
65	O	SELOE					95	I/O	$\overline{DB4}$				
66	—	V_{SS}					96	I/O	$\overline{DB3}$				
67	O	RSTOE					97	I/O	$\overline{DB2}$				
68	O	BSYOE					98	—	V_{SS}				
69	O	DBOE11					99	I/O	$\overline{DB1}$				
70	O	DBOE10					100	I/O	$\overline{DB0}$				
71	O	DBOE9					101	I/O	\overline{UDBP}				
72	O	DBOE8					102	—	V_{SS}				
73	—	V_{DD}					103	I/O	$\overline{DB15}$				
74	I/O	$\overline{DB11}$					104	I/O	$\overline{DB14}$				
75	I/O	$\overline{DB10}$					105	I/O	$\overline{DB13}$				
76	I/O	DB9					106	I/O	$\overline{DB12}$				
77	—	V_{SS}					107	—	V_{DD}				
78	I/O	$\overline{DB8}$					108	O	LDBOEP				
79	I/O	$\overline{I/O}$					109	O	DBOE7				
80	I/O	\overline{REQ}					110	O	DBOE6				
81	I/O	$\overline{C/D}$					111	O	DBOE5				
82	—	V_{SS}					112	—	V_{SS}				
83	I/O	\overline{SEL}					113	O	DBOE4				
84	I/O	\overline{MSG}					114	O	DBOE3				
85	I/O	\overline{RST}					115	O	DBOE2				
86	I/O	\overline{ACK}					116	—	V_{DD}				
87	I/O	\overline{BSY}					117	O	DBOE1				
88	—	V_{SS}					118	O	DBOE0				
89	I/O	\overline{ATN}					119	O	UDBOEP				
90	I/O	\overline{LDBP}					120	O	DBOE15				

(Continued)

MB86606

(Continued)

Pin no.	16-bit bus mode				PCI bus I/F mode		Pin no.	16-bit bus mode				PCI bus I/F mode		
	Mode 0 (68 I/F)		Mode 1 (80 I/F)		Mode 3 (PCI I/F)			Mode 0 (68 I/F)		Mode 1 (80 I/F)		Mode 3 (PCI I/F)		
	I/O	Pin name	I/O	Pin name	I/O	Pin name		I/O	Pin name	I/O	Pin name	I/O	Pin name	
121	O	DBOE14						133	I	DMLDS	I	DMWR	I/O	AD30
122	—	Vss						134	—	Vss				
123	O	DBOE13						135	I	DMR \overline{W}	I	DMRD	I/O	AD29
124	O	DBOE12						136	I/O	UDMDP		I/O	AD28	
125	I	DMA0			OD	SERR	137	—	VDD					
126	I	TP			I	PCLK	138	I/O	DMD15		I/O	AD27		
127	I	RESET						139	I/O	DMD14		I/O	AD26	
128	—	Vss						140	—	Vss				
129	I	DACK			I	GNT	141	I/O	DMD13		I/O	AD25		
130	O	DREQ			O	PREQ	142	I/O	DMD12		I/O	AD24		
131	—	VDD						143	I/O	DMD11		I/O	C/BE3	
132	I	DMUDS	I	DMBHE	I/O	AD31	144	I/O	DMD10		I	IDSEL		

I : Input pin

O : Output pin

I/O : Input/Output pin

IU : Input pin with pull-up resistor

OD : Open-drain output pin

■ PIN DESCRIPTION

1. SCSI Interface

Pin no.	Pin name	I/O	Function
84, 81 89, 79	$\overline{\text{MSG}}$, $\overline{\text{C/D}}$ $\overline{\text{ATN}}$, $\overline{\text{I/O}}$	I/O	These are the SCSI control signal input and output pins. They can be connected directly to a single-ended SCSI connector. Either open-drain or totem pole output can be selected.
80, 86	$\overline{\text{REQ}}$, $\overline{\text{ACK}}$	I/O	These are the SCSI control signal input and output pins. They can be connected directly to a single-ended SCSI connector. The output buffer is the totem pole type.
68 65 67	BSYOE SELOE RSTOE	O	These are used for output control of SCSI control signals. They should be used as control signals for the external differential driver/receiver circuit.
87 83 85	$\overline{\text{BSY}}$ $\overline{\text{SEL}}$ $\overline{\text{RST}}$	I/O	These are the SCSI control signal input and output pins. They can be connected directly to a single-ended SCSI connector. The output buffer is the open-drain type.
120, 121, 123, 124, 69 to 72 119 109 to 111, 113 to 115, 117, 118 108	DBOE15 to DBOE8 UDBOEP DBOE7 to DBOE0 LDBOEP	O	These are used for output control of SCSI data bus signals. They should be used as control signals for the external differential driver/receiver circuit.
103 to 106, 74 to 76, 78 101 91, 92, 94 to 97, 99, 100 90	$\overline{\text{DB15}}$ to $\overline{\text{DB8}}$ $\overline{\text{UDBP}}$ $\overline{\text{DB7}}$ to $\overline{\text{DB0}}$ $\overline{\text{LDBP}}$	I/O	These are used to input and output SCSI data bus signals. They can be connected directly to a single-ended SCSI connector. Either open-drain or totem pole output buffer can be selected.
64 62	INIT TARG	O	These are used to output signals indicating the chip operating status. They should be used as control signals for the external differential driver/receiver circuit.
61	$\overline{\text{S/DESL}}$	I	This is used to input signal for selecting the chip operation mode. Single-ended: Input 0 Differential-ended: Input 1 While 0 is input to this pin, all the SCSI control signals, data bus output control signals, INIT, and TARG signals are fixed with L level.
54	SCLK	I	This pin is used for a system clock input for SCSI protocol controller block. (Max. 40 MHz)

MB86606

2. 16-Bit Bus Mode-MPU Interface

Pin no.	Pin name	I/O	Function
48	$\overline{CS0}$	I	This is used to input signals for the MPU to select the SPC as the I/O device.
47	$\overline{CS1}$	I	This is used to input select signals (external circuit select signals) for the MPU to input and output the DMA data bus data via the SPC.
19, 20, 22 to 24, 26 to 28 17	D15 to D8 UDP	I/O	Upper byte and parity of data bus When $\overline{CS0}$ input valid: I/O ports for internal registers in SPC When $\overline{CS1}$ input valid: I/O ports for DMA bus data
29, 32 to 34, 36 to 39 41	D7 to D0 LDP	I/O	Lower byte and parity of data bus When $\overline{CS0}$ input valid: I/O ports for internal registers in SPC When $\overline{CS1}$ input valid: I/O ports for DMA bus data
51, 52, 55 to 57	A4 to A0	IU	These are used to input addresses for selecting the Internal registers.
46	\overline{RD} (R \overline{W})	I	In 80-series mode: This is used to input the read strobe signal for reading data from the SPC to the MPU. In 68-series mode: This is used to input the R \overline{W} control signal for reading and writing data from the MPU to the SPC.
44	\overline{WR} (LDS)	I	In 80-series mode: This is used to input the write strobe signal for writing data from the MPU to the SPC. In 68-series mode: This is used to input the \overline{LDS} signal output by the MPU when the lower byte of the data bus is valid.
42	\overline{BHE} (UDS)	I	In 80-series mode: This is used to input the \overline{BHE} signal output by the MPU when the upper byte of the data bus is valid. In 68-series mode: This is used to input the \overline{UDS} signal output by the MPU when the upper byte of the data bus is valid.

3. 16-Bit Bus Mode – DMA Interface

Pin no.	Pin name	I/O	Function
130	DREQ	O	This is used to output DMA transfer request signals to the DMAC. DMA data transfer between the SPC and memory is requested.
129	$\overline{\text{DACK}}$	I	This is used to input DMA-enabling signals from the DMAC. When the DMA enabling signal is active, DMA reading and writing are executed.
138, 139, 141 to 144, 1, 3 136	DMD15 to 8 UDMDP	I/O	Upper byte and parity of DMA data bus When CS1 input valid: The MPU data bus is directly connected. When 80-series mode: The 2nd data is input/output. When 68-series mode: The 1st data is input/output.
4, 5, 7, 9 to 11, 13, 14 15	DMD7 to 0 LDMDP	I/O	Lower byte and parity of DMA data bus When CS1 input valid: The MPU data bus is directly connected. When 80-series mode: The 1st data is input/output. When 68-series mode: The 2nd data is input/output.
135	$\overline{\text{DMRD}}$ (DMR/ $\overline{\text{W}}$)	I	In 80-series mode: This is used to input the $\overline{\text{IORD}}$ or $\overline{\text{RD}}$ signal for outputting data from the SPC to the DMA bus. In 68-series mode: This is used to input the $\overline{\text{R}/\overline{\text{W}}}$ control signal for outputting and inputting data from the DMAC to the SPC.
133	$\overline{\text{DMWR}}$ (DMLDS)	I	In 80-series mode: This is used to input the $\overline{\text{IOWR}}$ or $\overline{\text{WR}}$ signal for inputting data from the DMA bus to the SPC. In 68-series mode: This is used to input the $\overline{\text{LDS}}$ signal output by the DMAC when the lower byte of the DMA data bus is valid.
132	$\overline{\text{DMBHE}}$ (DMUDS)	I	In 80-series mode: This is used to input the $\overline{\text{BHE}}$ signal output by the DMAC when the upper byte of the DMA data bus is valid. In 68-series mode: This is used to input the $\overline{\text{UDS}}$ signal output by the DMAC when the upper byte of the DMA data bus is valid.
125	DMA0	I	This is used to input the address data A0 signal output by the DMAC in the 80-series mode. In 68-series mode: Connect to power supply pin (V_{DD}).
126	TP (Transfer permission)	I	This is used to input DMA-transfer-enabling signals. When the TP signal is active, the SPC performs the DMA transfer. When this signal becomes inactive during DMA transfer, the transfer stops temporarily at the block boundary.

MB86606

4. PCI Bus Interface Mode

Pin no.	Pin name	I/O	Function
130	$\overline{\text{PREQ}}$	O	This pin is used to request the bus arbiter for use of the bus.
129	$\overline{\text{GNT}}$	I	This is the response signal input pin to the $\overline{\text{REQ}}$ signal from the bus arbiter.
132, 133, 135, 136, 138, 139, 141, 142, 1, 3 to 5, 7, 9 to 11, 26 to 29, 32 to 34, 36, 38, 39, 41, 42, 44, 46 to 48	AD31 to AD0	I/O	PCI 32-bit address and data multiplexed pins
143, 13, 24, 37	$\text{C}/\overline{\text{BE}}_3$ to $\text{C}/\overline{\text{BE}}_0$	I/O	Bus command and Byte Enable signals multiplexed pins.
23	PAR	I/O	This is an even parity signal pin for the AD31 to AD0 and $\text{C}/\overline{\text{BE}}_3$ to $\text{C}/\overline{\text{BE}}_0$ signals. This PAR signal becomes valid after one clock.
14	$\overline{\text{FRAME}}$	I/O	This is a frame signal pin that indicates data are transferring on the bus.
17	$\overline{\text{TRDY}}$	I/O	Data Ready signal of Target side.
15	$\overline{\text{IRDY}}$	I/O	Data Ready signal of Initiator (Bus master) side.
20	$\overline{\text{STOP}}$	I/O	This is a stop request signal to stop the data transfer from target to master.
19	$\overline{\text{DEVSEL}}$	I/O	Device select pin. While the device is a target, this pin outputs the select signal that indicates the self device is selected. While the device is a master this pin functions as an input pin to indicate that a device on the bus is selected.
144	IDSEL	I	This is a chip select signal that indicates the configuration access.
126	PCLK	I	PCI bus clock input pin. The maximum clock frequency is 33 MHz.
22	$\overline{\text{PERR}}$	I/O	Data parity error input and output pin.
125	$\overline{\text{SERR}}$	OD	Address parity error output pin.

5. Other Signals

Pin No.	Pin name	I/O	Function															
127	RESET	O	This pin is used to input system reset signals.															
59, 60	MODE1, MODE0	I	<p>These pins are used for setting the device operation mode as listed in the table below.</p> <table border="1"> <thead> <tr> <th>MODE1</th> <th>MODE0</th> <th>Operation Mode</th> </tr> </thead> <tbody> <tr> <td>0</td> <td>0</td> <td>16-bit bus mode (68 series mode)</td> </tr> <tr> <td>0</td> <td>1</td> <td>16-bit bus mode (80 series mode)</td> </tr> <tr> <td>1</td> <td>0</td> <td>Reserved</td> </tr> <tr> <td>1</td> <td>1</td> <td>PCI bus interface mode</td> </tr> </tbody> </table>	MODE1	MODE0	Operation Mode	0	0	16-bit bus mode (68 series mode)	0	1	16-bit bus mode (80 series mode)	1	0	Reserved	1	1	PCI bus interface mode
MODE1	MODE0	Operation Mode																
0	0	16-bit bus mode (68 series mode)																
0	1	16-bit bus mode (80 series mode)																
1	0	Reserved																
1	1	PCI bus interface mode																
50	$\overline{\text{INT}}$	O/ OD	Interrupt output pin. Either totem pole or open-drain output buffer can be selected. This pin has an internal pull-up resistor.															
6, 18, 31, 43, 49, 63, 73, 107, 116, 131, 137	V _{DD}	—	Power supply pin															
2, 8, 12, 16, 21, 25, 30, 35, 40, 45, 53, 58, 66, 77, 82, 88, 93, 98, 102, 112, 122, 128, 134, 140	V _{SS}	—	Ground pin															
51, 52	PO1, PO0	O	General purpose output ports that can control the external active SCSI bus terminator etc. Initial signal level on each pin is "L". Those pins are available only for PCI bus interface mode.															
55, 56	PI1, PI0	IU	General purpose input ports. Available only for PCI bus interface mode.															
57	N.C.	—	No connection and unused pins. These pins exist on the only PCI bus mode. These are internally pulled-up, and do not connect to the pins.															

I : Input pin

O : Output pin

I/O : Input and Output pin

OD : Open-drain output pin

IU : Input pin with pull-up resistor

MB86606

■ BLOCK DIAGRAM

1. 16-Bit Bus Mode

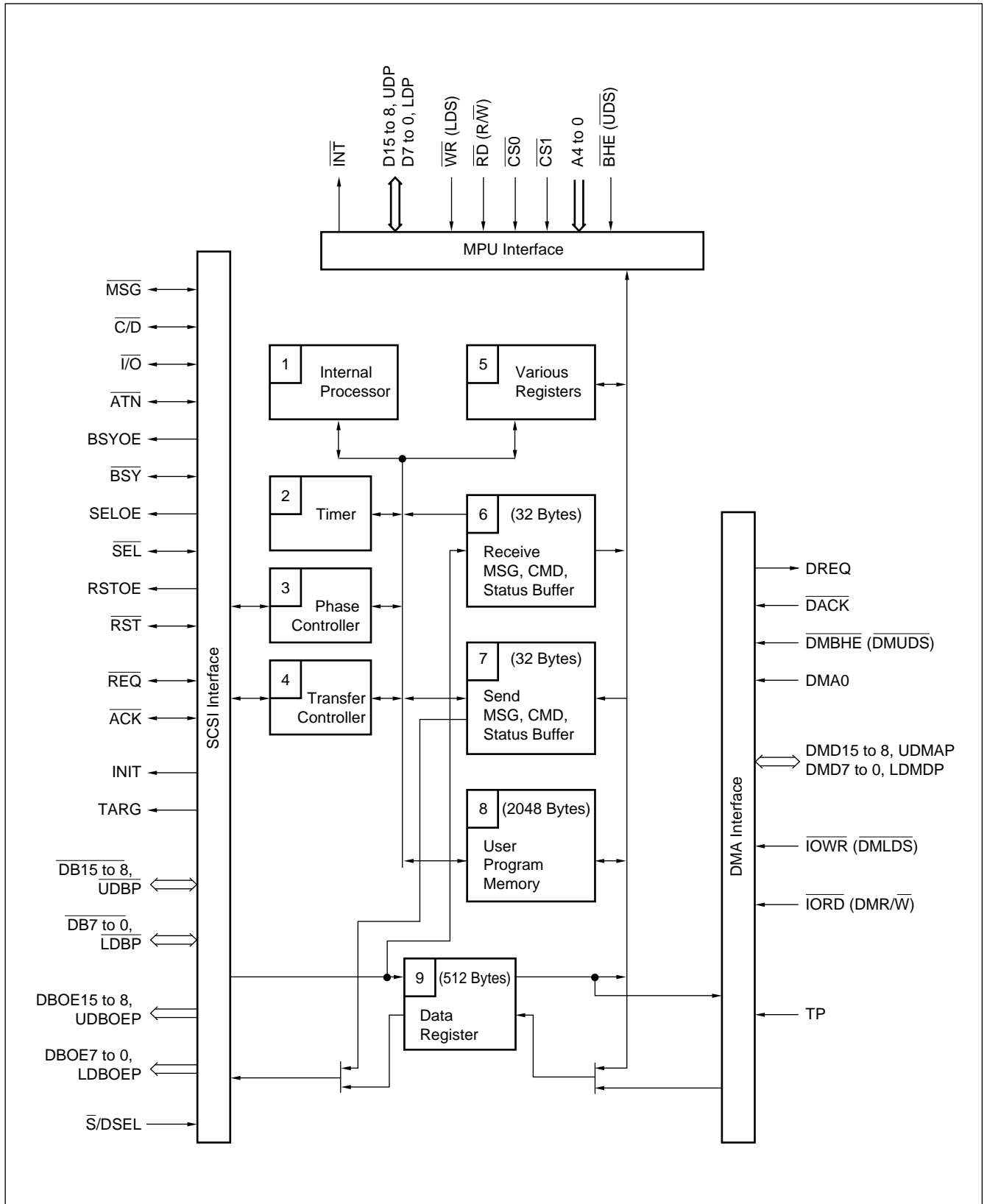

2. PCI Bus Interface Mode

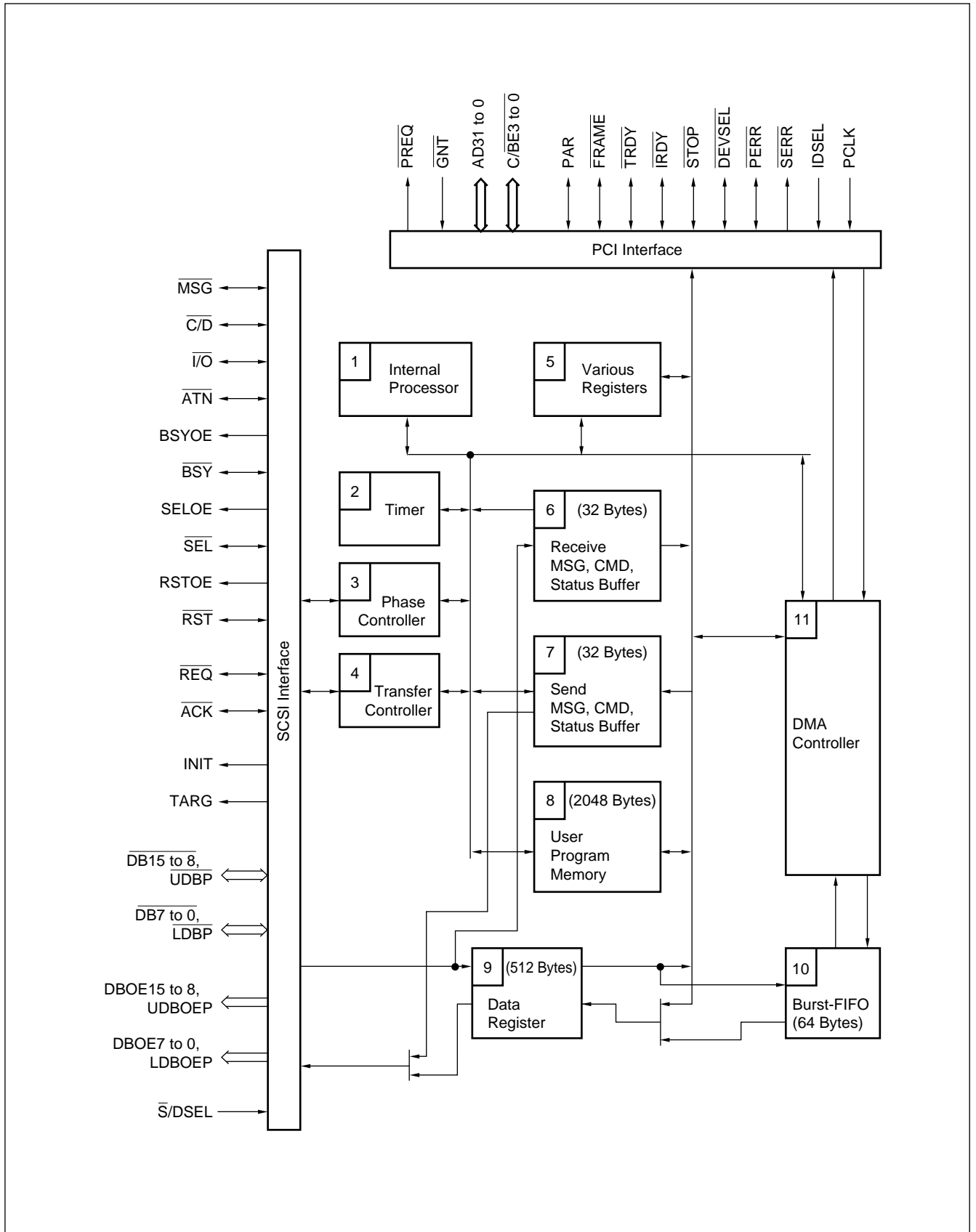

MB86606

■ BLOCK FUNCTIONS

1. Internal Processor

This processor provides the sequence control between each phase.

2. Timer

This timer manages the time specified by SCSI and the following time:

- REQ/ACK assertion time for data at asynchronous transfer
- Selection/reselection retry time
- Selection/reselection timeout time
- REQ/ACK timeout time during transfer

Asynchronous transfer (target)	:	Time required for initiator to assert ACK signal after asserting REQ signal
Asynchronous transfer (initiator)	:	Time required for target to negate REQ signal after asserting ACK signal
Synchronous transfer (target only)	:	Time required for target to receive ACK signal for setting offset value to 0 from initiator after sending REQ signal

3. Phase Controller

This controller controls the arbitration, selection/reselection, data-in/out, command, status, and message-in/out phases executed on the SCSI bus.

4. Transfer Controller

This controller controls the information (data, command, status, message) transfer phases executed on the SCSI bus.

There are two types of transfer for executing the information transfer phases.

- Asynchronous transfer : Control by interlocking REQ and ACK signals
- Synchronous transfer : Control with maximum of 32-byte offset value in data-in/out phase

Depending on the data migration, there are the following two modes.

- Program transfer : Performed via MPU interface using data registers
- DMA transfer : Performed via DMA interface using DREQ and $\overline{\text{DACK}}$ pins

At synchronous transfer, the transfer parameters (transfer mode, minimum cycle period of REQ or ACK signal sent from SPC in synchronous transfer, and maximum value between REQ and ACK signals in synchronous transfer) can be saved for each ID and are automatically set when the data phase is started. The transfer byte count is determined by block length \times number of blocks.

5. Various Registers

- **Command register**

This register specifies each command with an 8-bit code.

When using the user program, specify "1" at the Bit 7. The lower 7 bits (Bit 6 to Bit 0) are invalid.

- **Nexus status register**

This register indicates the chip's operating condition, the nexused partner's ID, and data register status.

- **SCSI control signal status register**

This register indicates the status of SCSI control signals.

- **Interrupt status register**

This register indicates the interrupt status with an 8-bit code.

- **Command step register**

This register indicates the execution status of each command with an 8-bit step code.

Error causes can be analyzed by referencing the interrupt status register and this register.

- **Group 6/7 command length setting register**

This register sets the group 6/7 command length not defined in the SCSI standard.

Setting this register determines the group 6/7 command length.

6. Receive MSG, CMD, Status Buffer (Receive MCS Buffer)

This is a 32-byte receive-only information buffer that holds the information for the message, command, and status received from the SCSI bus.

7. Send MSG, CMD, Status Buffer (Send MCS Buffer)

This is a 32-byte send-only information buffer that holds the information for the message, command, and status sent on the SCSI bus.

8. User Program Memory

This is a 2048-byte program memory that stores programmable commands. It can consist of 1024-byte \times 2 banks or 2048-byte \times 1 bank.

9. Data Register

This is a 512-byte FIFO data register that holds data in the data phase executed on the SCSI bus.

10. Burst FIFO

64-byte FIFO type data buffer to perform burst transfer during the PCI bus interface mode. The device has total 576-byte FIFO with Data Register and Burst FIFO in the PCI bus interface mode.

11. DMA Controller

This is a 32-bit DMA Controller that performs data transfer. This DMAC is a bus master during the PCI bus interface mode.

MB86606

■ ABSOLUTE MAXIMUM RATINGS

Parameter	Symbol	Rating		Unit
		Min.	Max.	
Supply voltage*	V_{DD}	$V_{SS}-0.5$	6.0	V
Input voltage*	V_I	$V_{SS}-0.5$	$V_{DD}+0.5$	V
Output voltage*	V_O	$V_{SS}-0.5$	$V_{DD}+0.5$	V
Operating ambient temperature	T_{op}	-25	+85	°C
Storage temperature	T_{stg}	-40	+125	°C

* : The voltages are based on V_{SS} (= 0V)

Note: Permanent device damage may occur if the above Absolute Maximum Ratings are exceeded. Functional operation should be restricted to the conditions as detailed in the operational sections of this data sheet. Exposure to absolute maximum rating conditions for extended periods may affect device reliability.

■ RECOMMENDED OPERATING CONDITIONS

Parameter	Symbol	Value			Unit
		Min.	Typ.	Max.	
Supply voltage*	V_{DD}	4.75	5.0	5.25	V
SCSI clock input frequency	f_{SCSI}	20.0	—	40.0	MHz
PCI clock input frequency	f_{PCI}	—	—	33.0	MHz
Operating temperature	T_a	0	—	+70	°C

* : The voltages are based on V_{SS} (= 0V)

Note: The recommended operating conditions are the recommended values for assuring normal logic operation of the LSI. Requirements in electrical characteristics (DC and AC characteristics) are assured within the range of the recommended operating conditions.

■ ELECTRICAL CHARACTERISTICS

1. DC Characteristics

($V_{DD} = +5 V \pm 5\%$, $V_{SS} = 0 V$, $T_a = 0$ to $+70^\circ C$)

Parameter				Symbol	Condition	Value		Unit	
						Min.	Max.		
Input voltage*1	SCSI pins			V_{IH}	—	1.9	—	V	
				V_{IL}	—	—	1.0	V	
	SCLK pins SDSEL pins			V_{IH}	—	2.4	—	V	
				V_{IL}	—	—	0.8	V	
	Other pins			V_{IH}	—	2.0	—	V	
				V_{IL}	—	—	0.8	V	
SCSI-pin input hysteresis*1				V_{HW}	—	0.3	—	V	
Output voltage*1	SCSI pins	In single-end mode	REQ, ACK		V_{OH}	$I_{OH} = -7.0$ mA	2.0	3.24	V
					V_{OL}	$I_{OL} = +48.0$ mA	—	0.5	V
			RST, BSY, SEL		V_{OL}	$I_{OL} = +48.0$ mA	—	0.5	V
			Others	Non-3ST.	V_{OL}	$I_{OL} = +48.0$ mA	—	0.5	V
				3ST.	V_{OH}	$I_{OH} = -7.0$ mA	2.0	3.24	V
			V_{OL}		$I_{OL} = +48.0$ mA	—	0.5	V	
	In differential mode		V_{OH}	$I_{OH} = -7.0$ mA	2.0	3.24	V		
			V_{OL}	$I_{OL} = +3.2$ mA	—	0.4	V		
	PCI bus interface pins			V_{OH}	$I_{OH} = -2.0$ mA	4.2	—	V	
				V_{OL}	$I_{OL} = +6.0$ mA	—	0.55	V	
	Other pins			V_{OH}	$I_{OH} = -2.0$ mA	4.2	—	V	
				V_{OL}	$I_{OL} = +3.2$ mA	—	0.4	V	
Input leakage current				I_{LI}	$V_{IN} = 0$ to V_{DD}	-10	+10	μA	
Input/output leakage current*2				I_{LOZ}	$V_{IN} = 0$ to V_{DD}	-10	+10	μA	
Supply current				I_{DD}	—	—	150	mA	

3ST. : Three-state mode

*1 : SCSI pins are; \overline{UDBP} , $\overline{DB15}$ to $\overline{DB8}$, \overline{LDBP} , $\overline{DB7}$ to $\overline{DB0}$, BSY, SEL, RST, ATN, REQ, ACK, \overline{MSG} , $\overline{C/D}$ and $\overline{I/O}$. (Total 27 pins)

*2 : Leak current when the three-state output pin output and the bidirectional bus pin output are in a high impedance state.

MB86606

2. Input/Output Pin Capacitance

($V_{DD} = V_{IN} = 0\text{ V}$, $f = 1\text{ MHz}$, $T_a = +25^\circ\text{C}$)

Parameter	Pin name	Symbol	Conditions		Unit
			Min.	Max.	
Input-pin capacitance	SCLK, PCLK (TP)	C_{IN}	—	12	pF
	Other input pins		—	8	pF
Output-pin capacitance		C_{OUT}	—	10	pF
Input/output-pin capacitance	Non-SCSI pins	$C_{I/O}$	—	10	pF
	SCSI pins		—	25	pF

3. Load Conditions for Measurement of AC Characteristics

(1) Non-SCSI pins

($V_{DD} = +5\text{ V} \pm 5\%$, $V_{SS} = 0\text{ V}$, $T_a = 0\text{ to } +70^\circ\text{C}$)

16-bit bus mode

Pin name	C_L
INT, DREQ	60 pF
D15 to D8, UDP, D7 to D0, LDP, DMD15 to DMD8, UDMDP, DMD7 to DMD0, LDMDP	85 pF

PCI bus interface mode

Pin name	C_L
PCI bus pins	50 pF

(2) SCSI pins

($V_{DD} = +5\text{ V} \pm 5\%$, $V_{SS} = 0\text{ V}$, $T_a = 0\text{ to } +70^\circ\text{C}$)

Load resistance	$R_{L1} = 110\ \Omega$
	$R_{L2} = 165\ \Omega$
Load capacitance	$C_L = 200\ \text{pF}$

4. AC Characteristics

(1) System clock

• SCSI clock (SCLK pin)

Parameter	Symbol	Value			Unit
		Min.	Typ.	Max.	
Clock period	t_{CLF}	25.0	—	50.0	ns
Clock pulse width (Low)	t_{CLCH}	10.0	—	—	ns
Clock pulse width (High)	t_{CHCL}	10.0	—	—	ns
Clock pulse rise time	t_{CR}	—	—	5.0	ns
Clock pulse fall time	t_{CF}	—	—	5.0	ns

Note: When the internal operating clock frequency is the same as the input clock frequency, (when using the device in divide-by-1 mode), the clock pulse width for L and H levels must have minimum 20.0 ns or longer. (i.e. When the clock conversion register value is 0Bh (address: 10h in the initial setting registers) and input clock frequency = 20 MHz.)

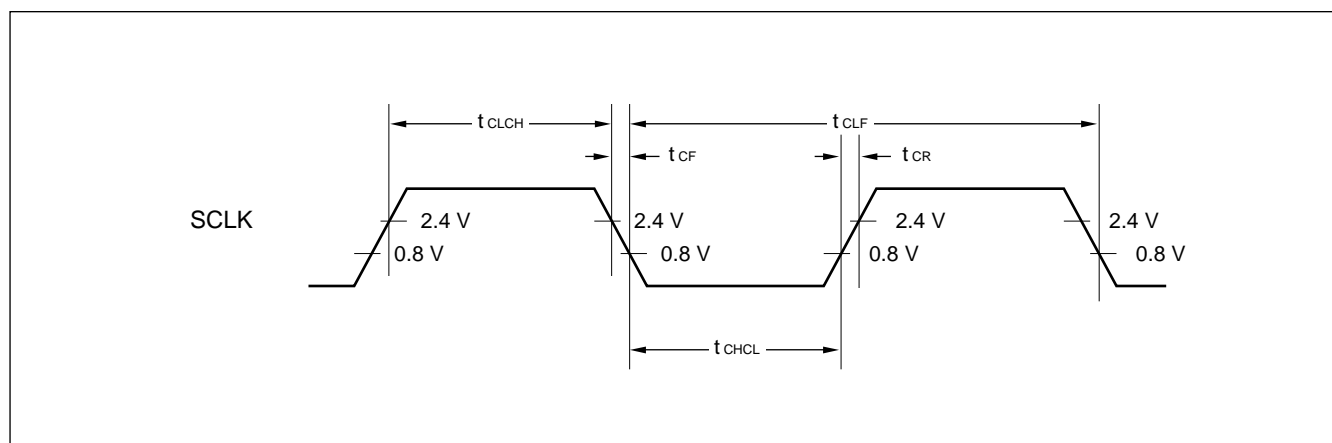

MB86606

• PCI clock (PCLK pin)

Parameter	Symbol	Value			Unit
		Min.	Typ.	Max.	
Clock frequency	t_{PCY}	30.0	—	—	ns
Clock pulse width (Low)	t_{PLO}	12.0	—	—	ns
Clock pulse width (High)	t_{PHI}	12.0	—	—	ns
Clock slew rate	t_{PSR}	1.0	—	4.0	V/ns
Clock amplitude	$V_{IHP} - V_{ILP}$	2.0	—	—	V

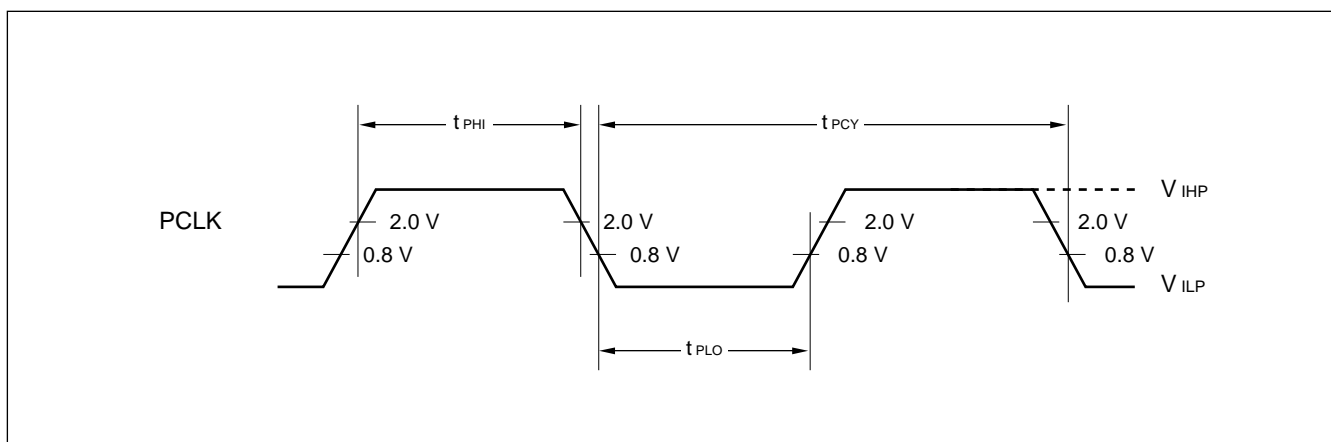

(2) System reset

Parameter	Symbol	Value			Unit
		Min.	Typ.	Max.	
Reset ($\overline{\text{RESET}}$) pulse "L" level pulse width	t_{WRSL}	$4 t_{CLF}$	—	—	ns

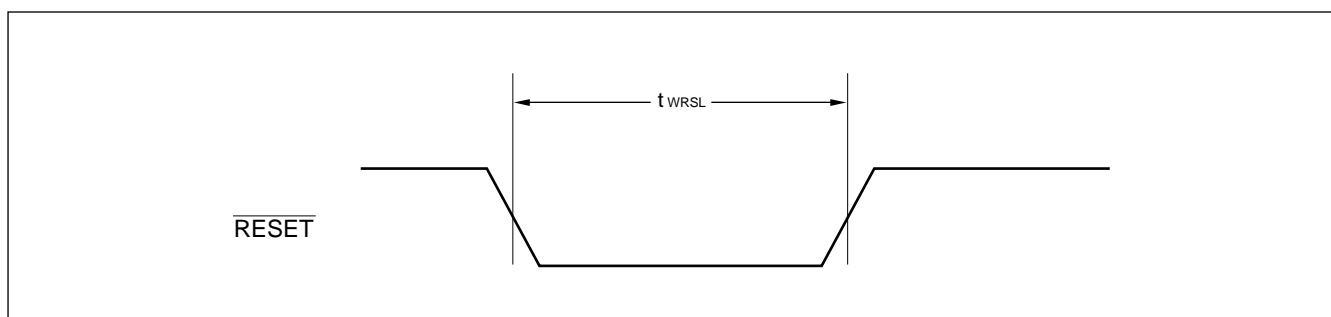

5. MPU Interface

(1) Register write timing for 80 series

Parameter	Symbol	Value		Unit
		Min.	Max.	
Address (A4 to A0), $\overline{\text{BHE}}$ setup time	t_{AWS}	20	—	ns
Address (A4 to A0) hold time	t_{AWH}	10	—	ns
$\overline{\text{CS0}}$ setup time	t_{CWS}	10	—	ns
$\overline{\text{CS0}}$ hold time	t_{CWH}	5	—	ns
Data set up time	t_{DWS}	25	—	ns
Data hold time	t_{DWH}	10	—	ns
$\overline{\text{WR}}$ "L" level pulse width	t_{WR}	70	—	ns

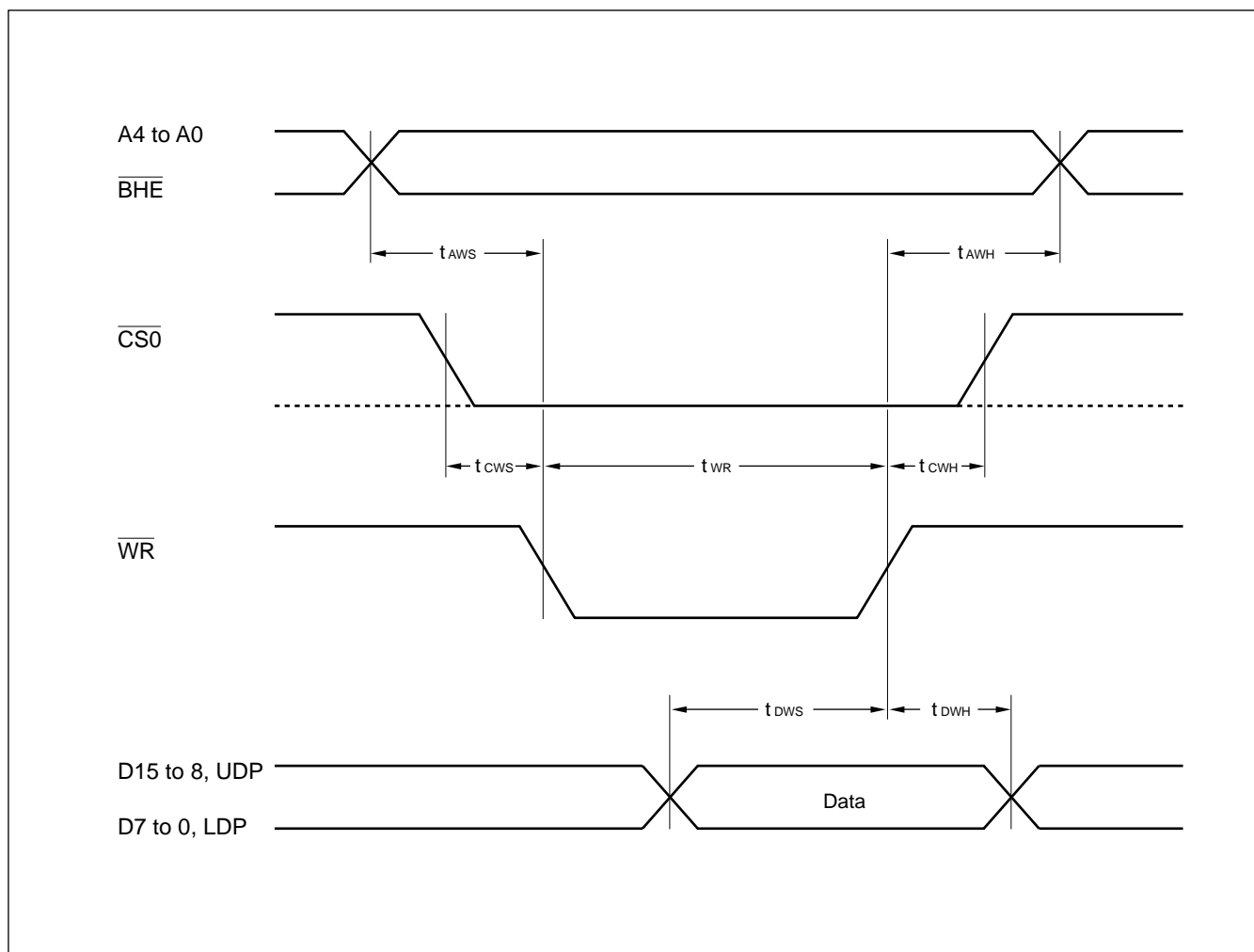

MB86606

(2) Resistor read timing for 80 series

Parameter	Symbol	Value		Unit
		Min.	Max.	
Address (A4 to A0), $\overline{\text{BHE}}$ setup time	t_{ARS}	20	—	ns
Address (A4 to A0) hold time	t_{ARH}	10	—	ns
$\overline{\text{CS0}}$ setup time	t_{CRS}	10	—	ns
$\overline{\text{CS0}}$ hold time	t_{CRH}	5	—	ns
$\overline{\text{RD}}$ set Low → data output defined time	t_{RLD}	—	40	ns
$\overline{\text{RD}}$ set High → data output defined time	t_{RHD}	5	—	ns
$\overline{\text{RD}}$ pulse duration at Low	t_{RD}	70	—	ns
INT signal clear time	Interrupt non-hold mode	t_{DL}	50	ns
	Interrupt hold mode	t_{DL2}	$n \cdot t_{\text{CLF}} + 50$	ns

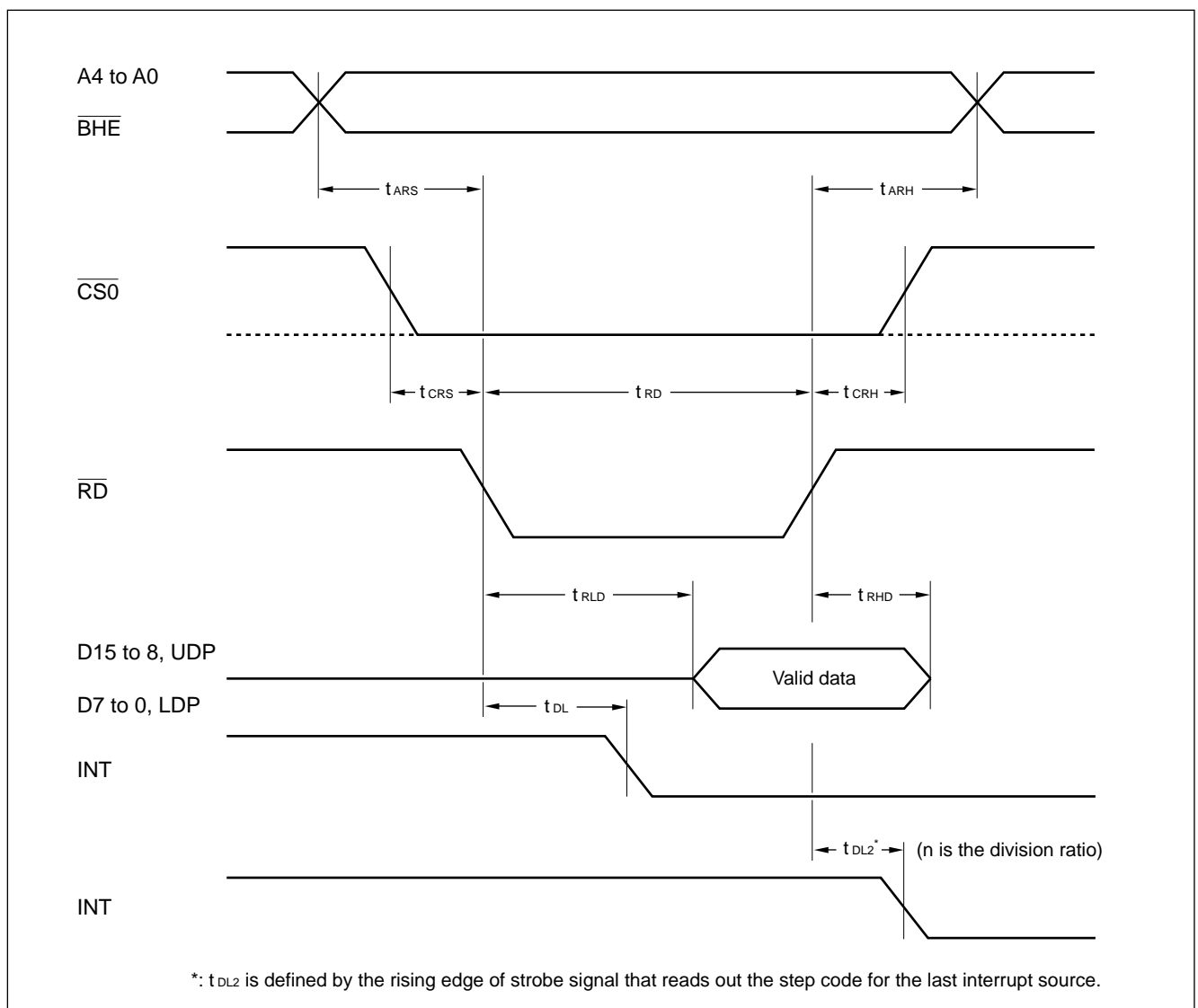

(3) Register write timing for 80 series (for external access)

Parameter	Symbol	Value		Unit
		Min.	Max.	
Address (A0), $\overline{\text{BHE}}$ setup time	t_{AWSE}	20	—	ns
Address (A0), $\overline{\text{BHE}}$ hold time	t_{AWHE}	10	—	ns
$\overline{\text{CS1}}$ setup time	t_{CWSE}	10	—	ns
$\overline{\text{CS1}}$ hold time	t_{CWHE}	5	—	ns
$\overline{\text{WR}}$ set Low \rightarrow DMA bus output delay time	t_{WLHD}	—	40	ns
$\overline{\text{WR}}$ set High \rightarrow DMA bus output undefined time	t_{WHHD}	5	—	ns
MPU data bus \rightarrow DMA bus output delay time	t_{DHD}	—	20	ns

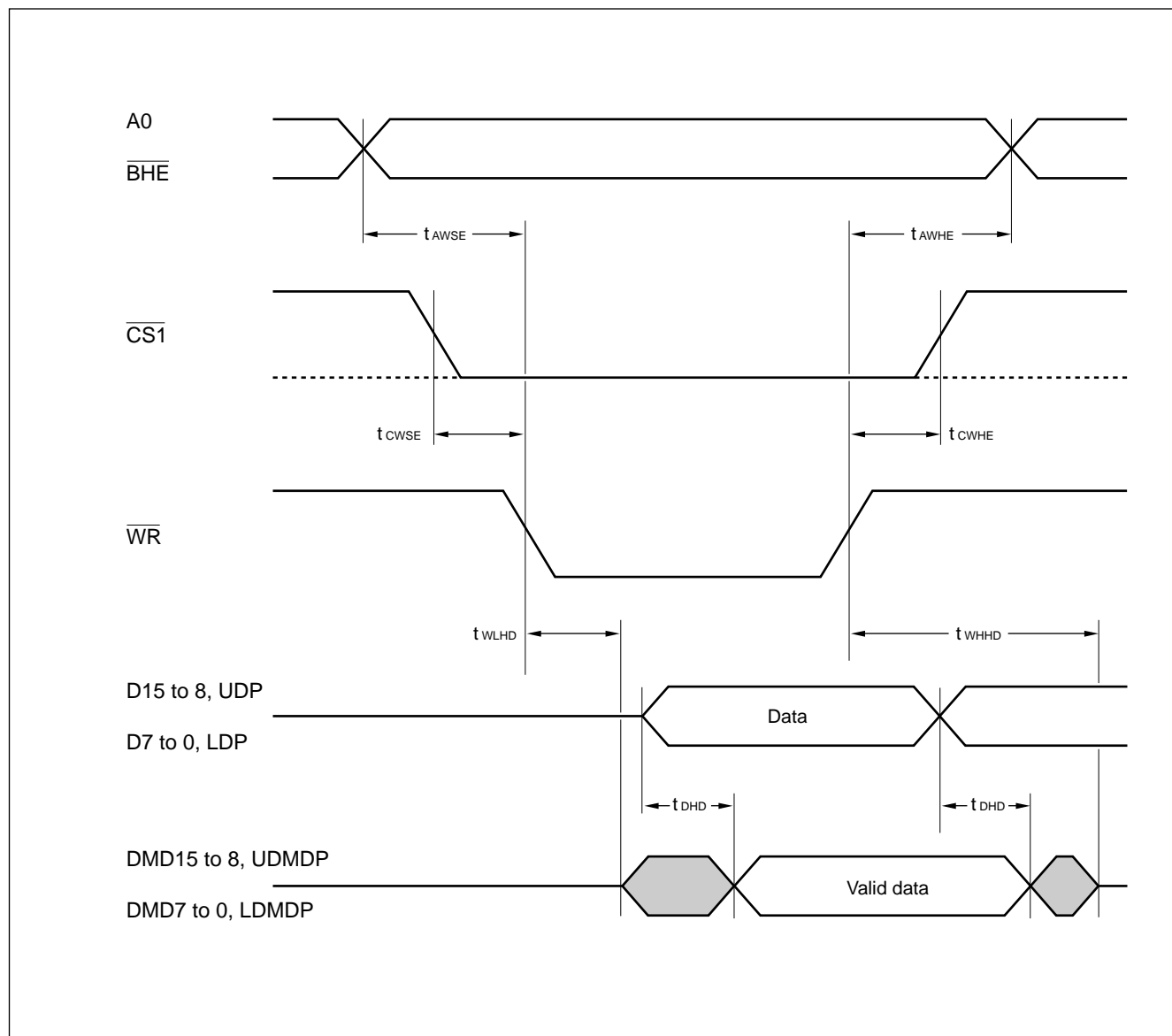

MB86606

(4) Register read timing for 80 series (for external access)

Parameter	Symbol	Value		Unit
		Min.	Max.	
Address (A0), $\overline{\text{BHE}}$ setup time	t_{ARSE}	20	—	ns
Address (A0), $\overline{\text{BHE}}$ hold time	t_{ARHE}	10	—	ns
$\overline{\text{CS1}}$ setup time	t_{CRSE}	10	—	ns
$\overline{\text{CS1}}$ hold time	t_{CRHE}	5	—	ns
$\overline{\text{RD}}$ set Low → MPU bus output enable time	t_{RLNZ}	—	40	ns
$\overline{\text{RD}}$ set High → MPU bus output disable time	t_{RHHZ}	5	—	ns
DMA data bus → MPU bus output delay time	t_{HDD}	—	20	ns

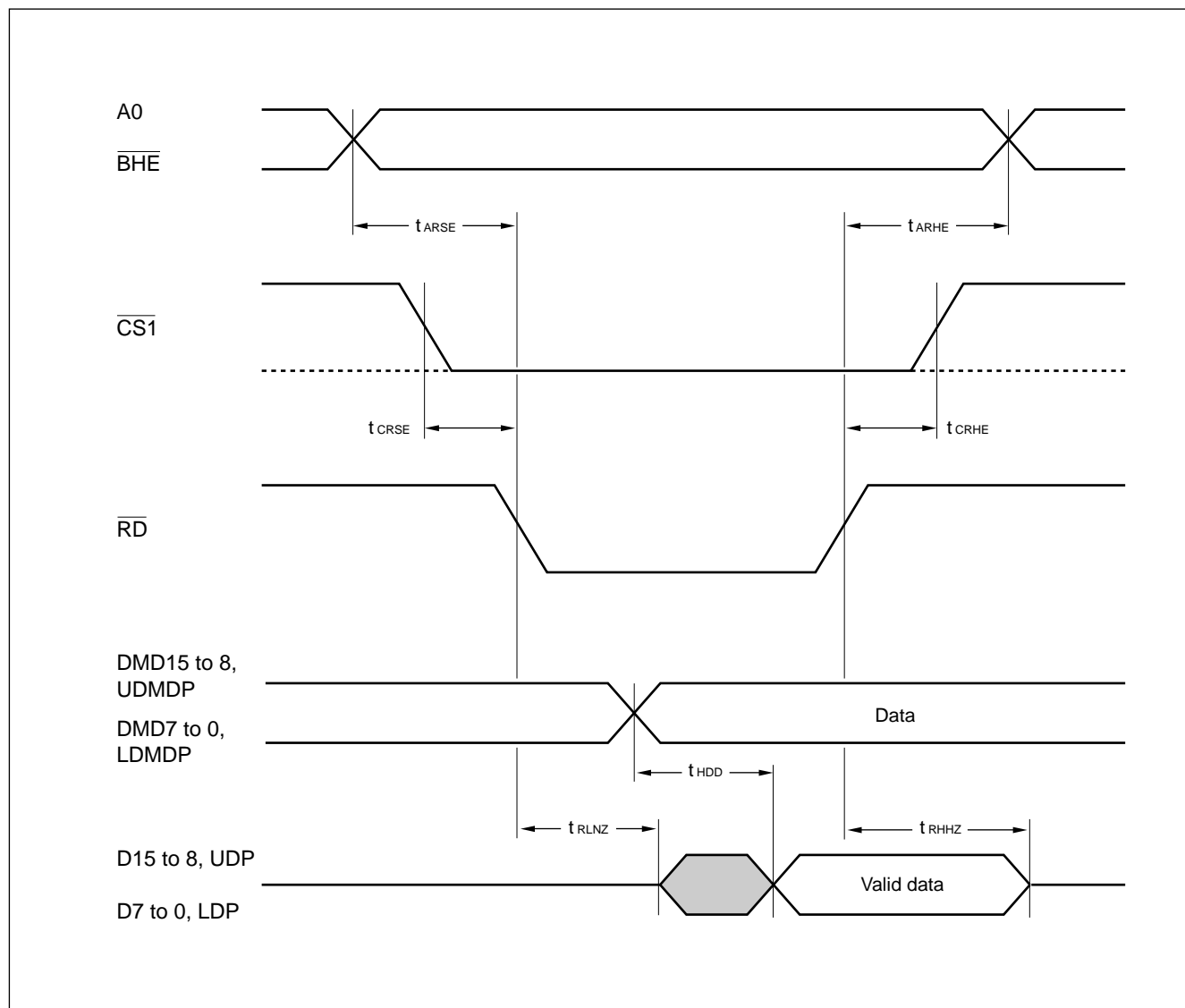

(5) Register write timing for 68 series

Parameter	Symbol	Value		Unit
		Min.	Max.	
Address (A4 to A0) setup time	t_{AWS}	20	—	ns
Address (A4 to A0) hold time	t_{AWH}	10	—	ns
$\overline{CS0}$ setup time	t_{CWS}	10	—	ns
$\overline{CS0}$ hold time	t_{CWH}	5	—	ns
Data setup time	t_{DWS}	25	—	ns
Data hold time	t_{DWH}	10	—	ns
$\overline{UDS}/\overline{LDS}$ "L" level pulse width	t_{DS}	70	—	ns
R/\overline{W} setup time	t_{RWS}	10	—	ns
R/\overline{W} hold time	t_{RWH}	10	—	ns

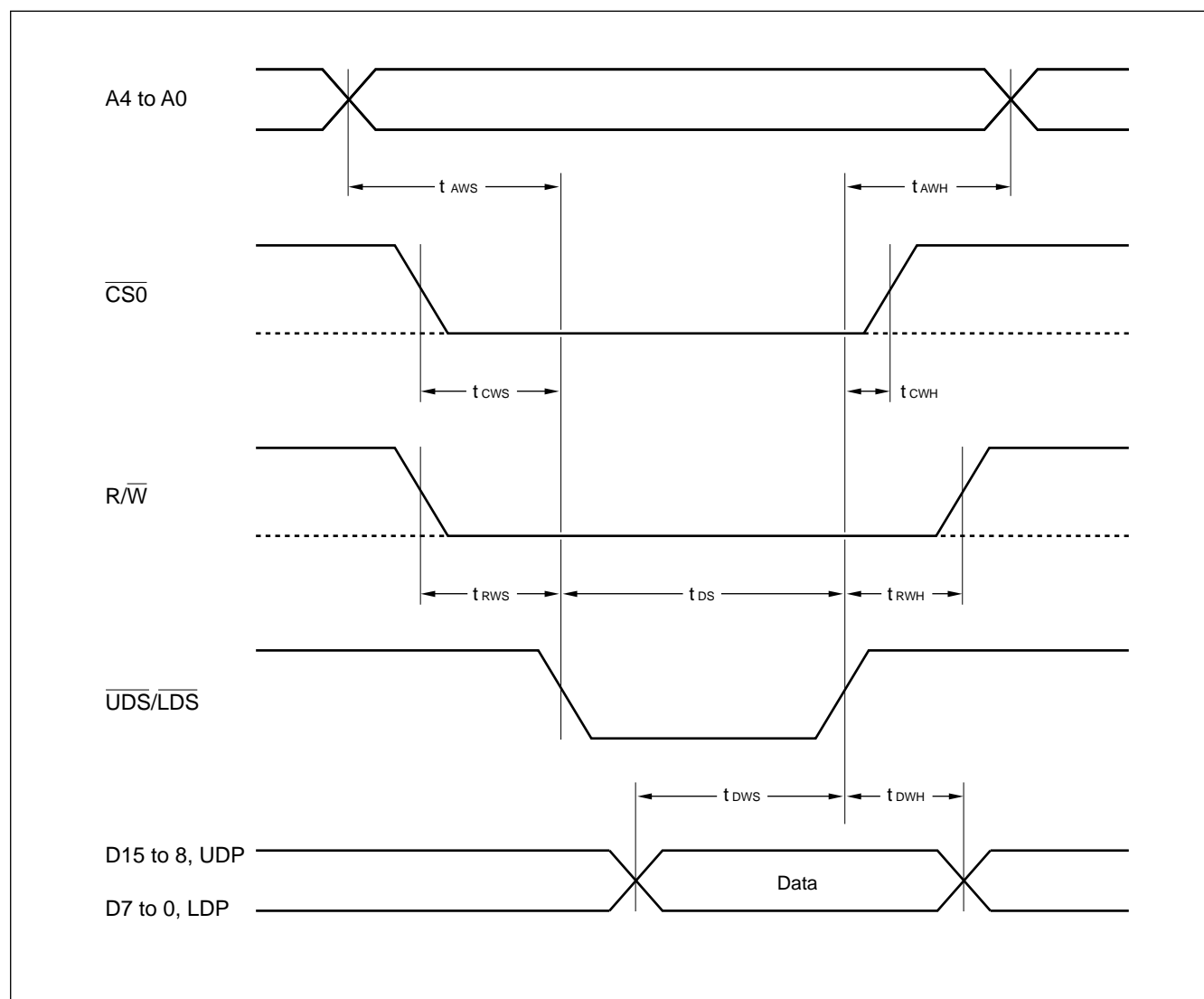

MB86606

(6) Register read timing for 68 series

Parameter	Symbol	Value		Unit
		Min.	Max.	
Address (A4 to A0) setup time	t_{ARS}	20	—	ns
Address (A4 to A0) hold time	t_{ARH}	10	—	ns
$\overline{CS0}$ setup time	t_{CRS}	10	—	ns
$\overline{CS0}$ hold time	t_{CRH}	5	—	ns
Data output defined time	t_{RLD}	—	40	ns
Data output disable time	t_{RHD}	5	—	ns
$\overline{UDS}/\overline{LDS}$ "L" level pulse width	t_{DS}	70	—	ns
R/\overline{W} setup time	t_{RWS}	10	—	ns
R/\overline{W} hold time	t_{RWH}	10	—	ns
\overline{INT} signal clear time	t_{DH}	—	50	ns
	t_{DH2}	—	$n \cdot t_{CLK} + 50$	

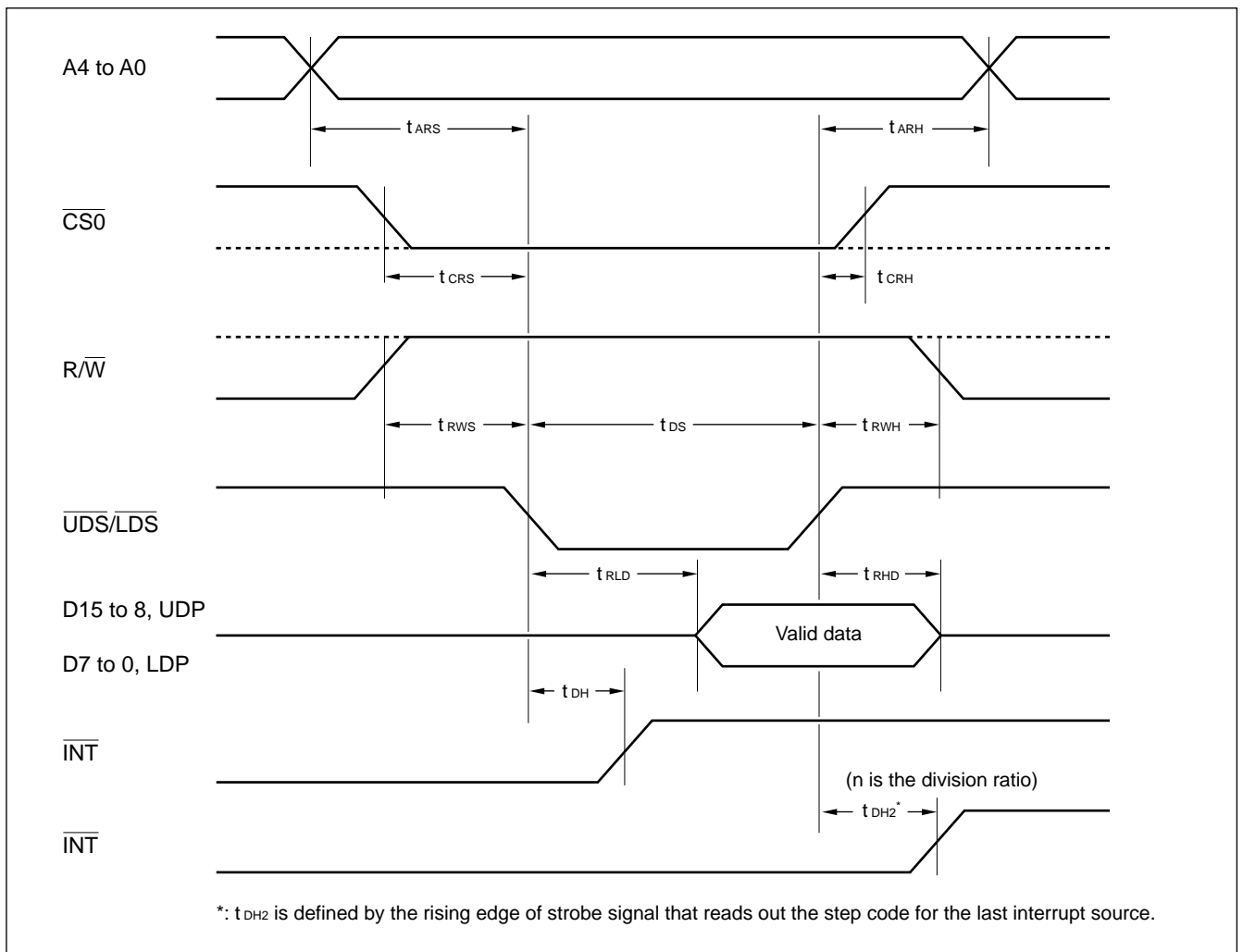

(7) Register write timing for 68 series (for external access)

Parameter	Symbol	Value		Unit
		Min.	Max.	
Address (A0) setup time	t_{AWSE}	20	—	ns
Address (A0) hold time	t_{AWHE}	10	—	ns
$\overline{CS1}$ setup time	t_{CWSE}	10	—	ns
$\overline{CS1}$ hold time	t_{CWHE}	5	—	ns
$\overline{UDS}/\overline{LDS}$ set Low \rightarrow DMA bus output delay time	t_{WLHD}	—	40	ns
$\overline{UDS}/\overline{LDS}$ set High \rightarrow DMA bus output undefined time	t_{WHHD}	5	—	ns
MPU data bus \rightarrow DMA bus output delay time	t_{DHD}	—	20	ns
R/\overline{W} setup time	t_{RWS}	10	—	ns
R/\overline{W} hold time	t_{RWH}	10	—	ns

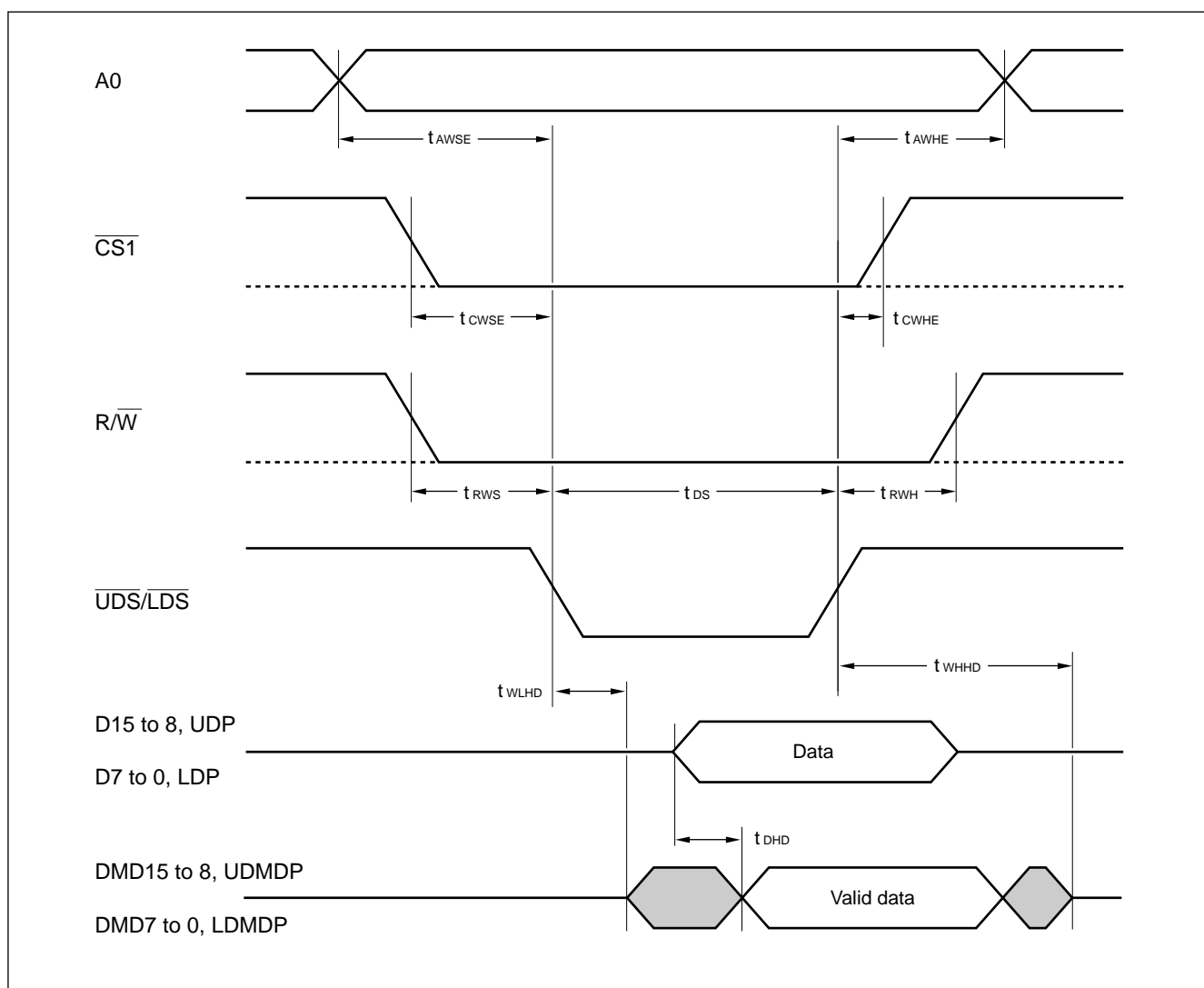

MB86606

(8) Register read timing for 68 series (for external access)

Parameter	Symbol	Value		Unit
		Min.	Max.	
Address (A0) setup time	t_{ARSE}	20	—	ns
Address (A0) hold time	t_{ARHE}	10	—	ns
$\overline{CS1}$ setup time	t_{CRSE}	10	—	ns
$\overline{CS1}$ hold time	t_{CRHE}	5	—	ns
$\overline{UDS}/\overline{LDS}$ set Low \rightarrow MPU data bus output enable time	t_{RLNZ}	—	40	ns
$\overline{UDS}/\overline{LDS}$ set High \rightarrow MPU data bus output disable time	t_{RHH}	5	—	ns
DMA bus \rightarrow MPU data bus output delay time	t_{HDD}	—	20	ns
R/ \overline{W} setup time	t_{RWS}	10	—	ns
R/ \overline{W} hold time	t_{RWH}	10	—	ns

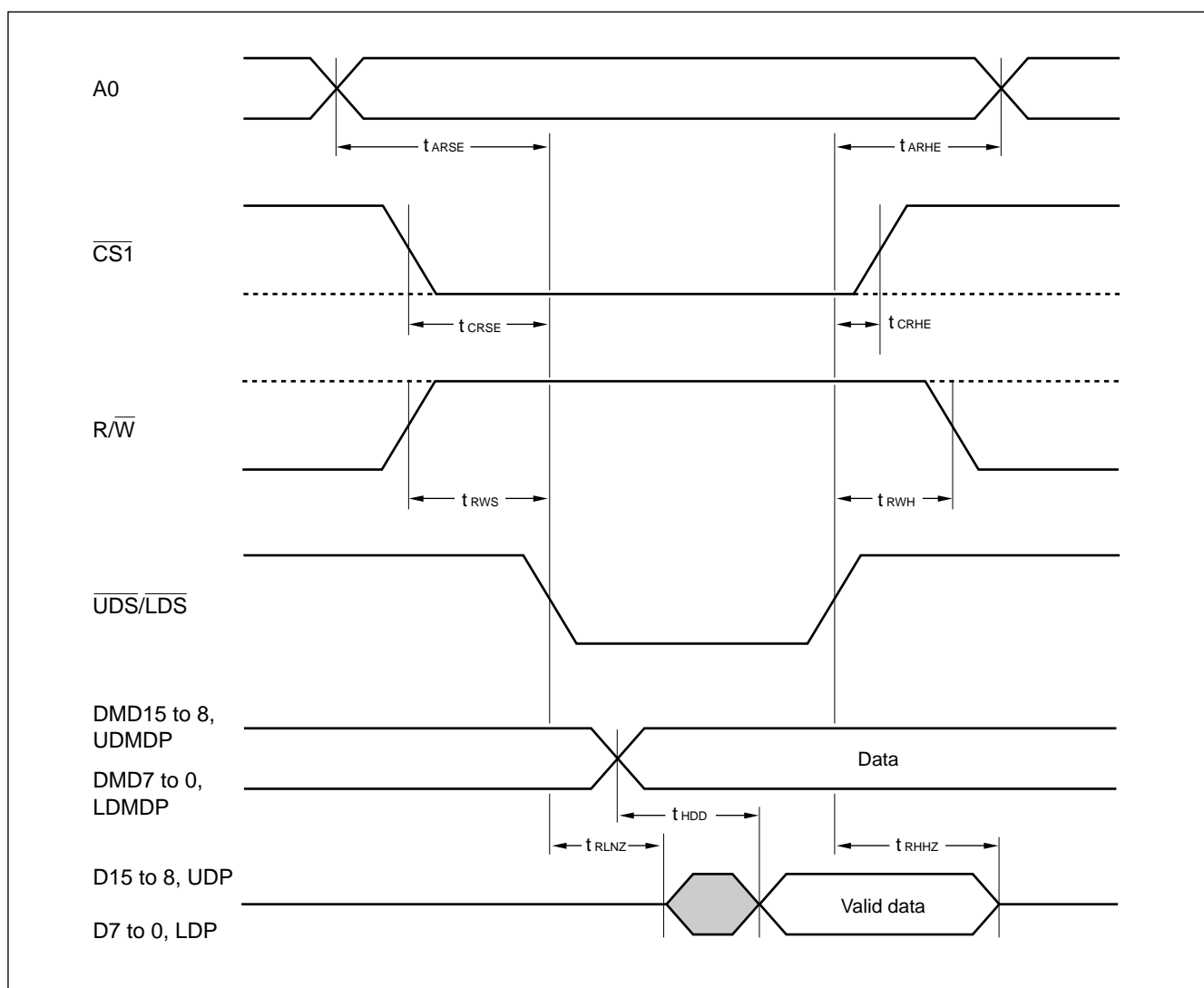

6. DMA Interface

DMA access timing

The time regulations are not applicable in the following cases:

- During SCSI input and when data buffer EMPTY, or when one byte held
- During SCSI output and when data buffer FULL, or when 511 bytes held
- When parity error detected (target)
- When error stopping transfer occurs in SCSI interface

(1) Access cycle time (burst mode)

Parameter	Symbol	Value		Unit
		Min.	Max.	
Address cycle time	t _{DCY1}	2 t _{CLF}	—	ns
	t _{DCY2}	3 t _{CLF}	—	ns
	t _{DCY3}	4 t _{CLF}	—	ns
	t _{DCY4}	1 t _{CLF}	—	ns

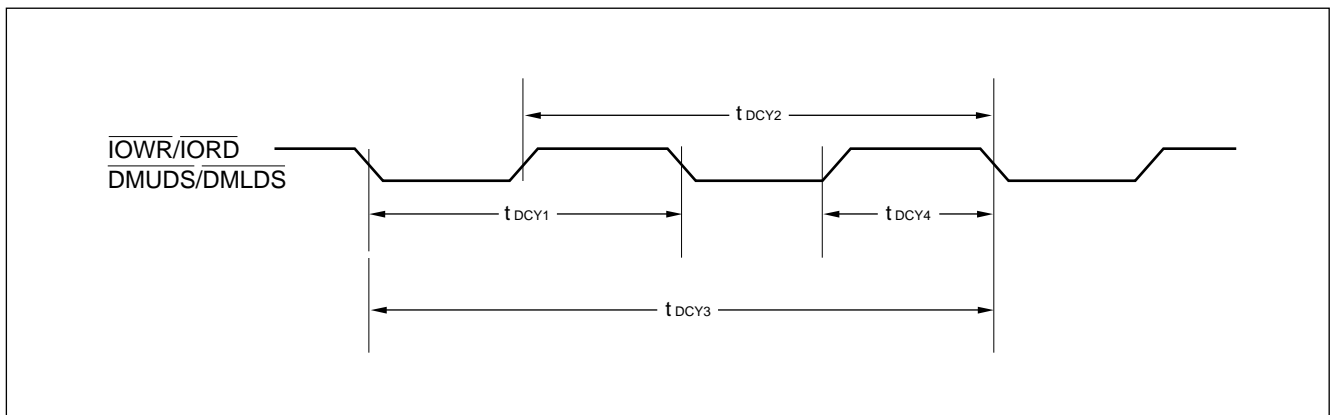

MB86606

(2) Write timing (burst mode for 80 series)

Parameter	Symbol	Value		Unit
		Min.	Max.	
DREQ set High → $\overline{\text{DACK}}$ set Low	t_{DHAL}	0	—	ns
$\overline{\text{IOWR}}$ set Low → DREQ set Low	t_{ALDL}	—	25	ns
DREQ set Low → DREQ set High	t_{DLDH}	0	—	ns
$\overline{\text{DACK}}$ set Low → $\overline{\text{IOWR}}$ set Low	t_{ALWL}	0	—	ns
$\overline{\text{DMBHE}}$, DMA0 setup time	t_{DAWS}	10	—	ns
$\overline{\text{IOWR}}$ "L" level pulse width	t_{DWR}	25	—	ns
$\overline{\text{IOWR}}$ set High → $\overline{\text{DACK}}$ set High	t_{WHAH}	0	—	ns
$\overline{\text{DMBHE}}$, DMA0 hold time	t_{DAWH}	10	—	ns
Input data setup time	t_{DDWS}	25	—	ns
Input data hold time	t_{DDWH}	5	—	ns

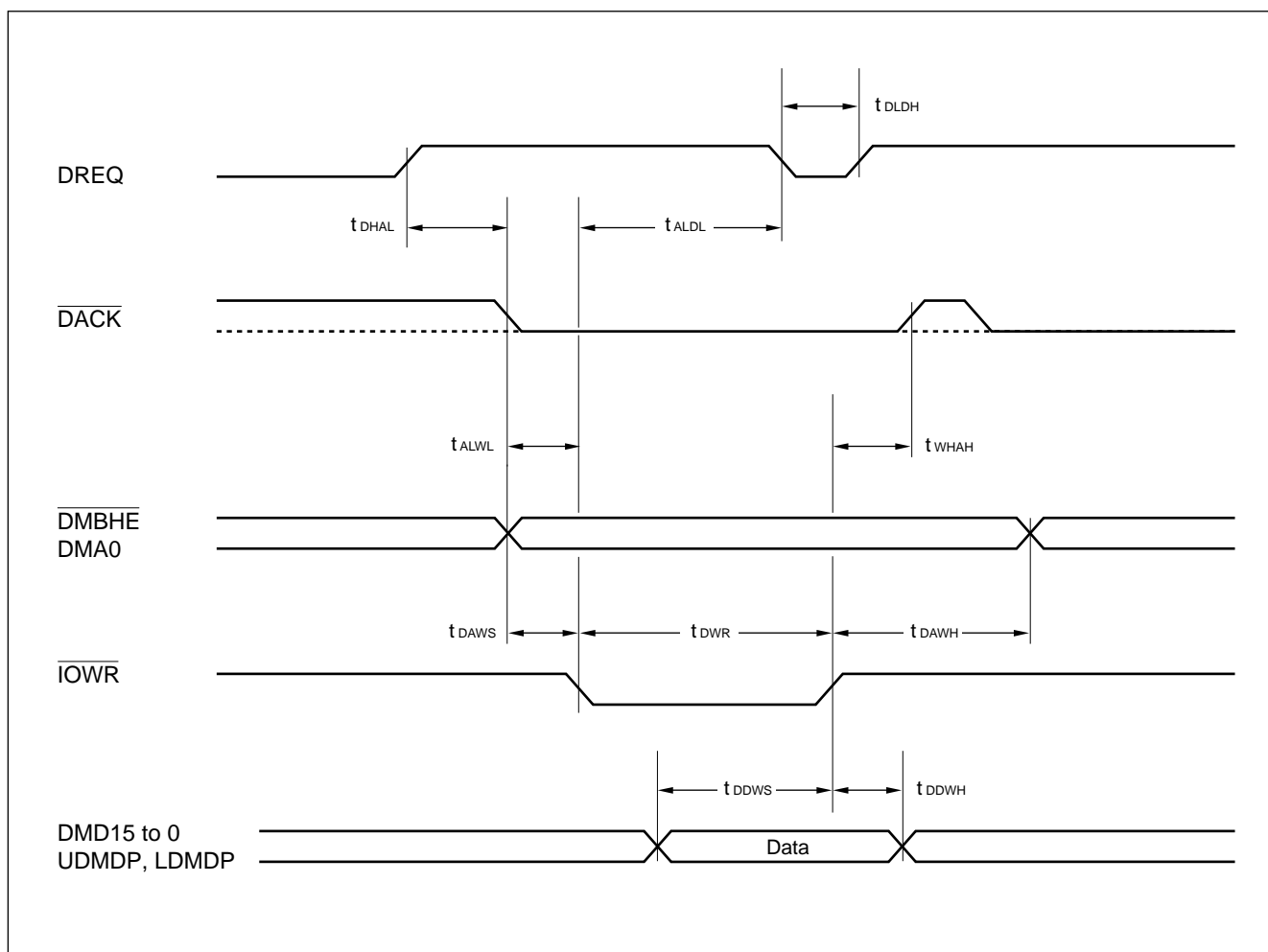

(3) Read timing (burst mode for 80 series)

Parameter	Symbol	Value		Unit
		Min.	Max.	
DREQ set High → $\overline{\text{DACK}}$ set Low	t_{DHAL}	0	—	ns
$\overline{\text{IORD}}$ set Low → DREQ set Low	t_{ALDL}	—	25	ns
DREQ set Low → DREQ set High	t_{DLDH}	0	—	ns
$\overline{\text{DACK}}$ set Low → $\overline{\text{IORD}}$ set Low	t_{ALRL}	0	—	ns
$\overline{\text{DMBHE}}$, DMA0 setup time	t_{DARS}	10	—	ns
$\overline{\text{IORD}}$ "L" level pulse width	t_{DRD}	25	—	ns
$\overline{\text{IORD}}$ set High → $\overline{\text{DACK}}$ set High	t_{RHAH}	0	—	ns
$\overline{\text{DMBHE}}$, DMA0 hold time	t_{DARH}	10	—	ns
Data output defined time	t_{DRLD}	—	25	ns
Data output hold time	t_{DRHD}	10	—	ns

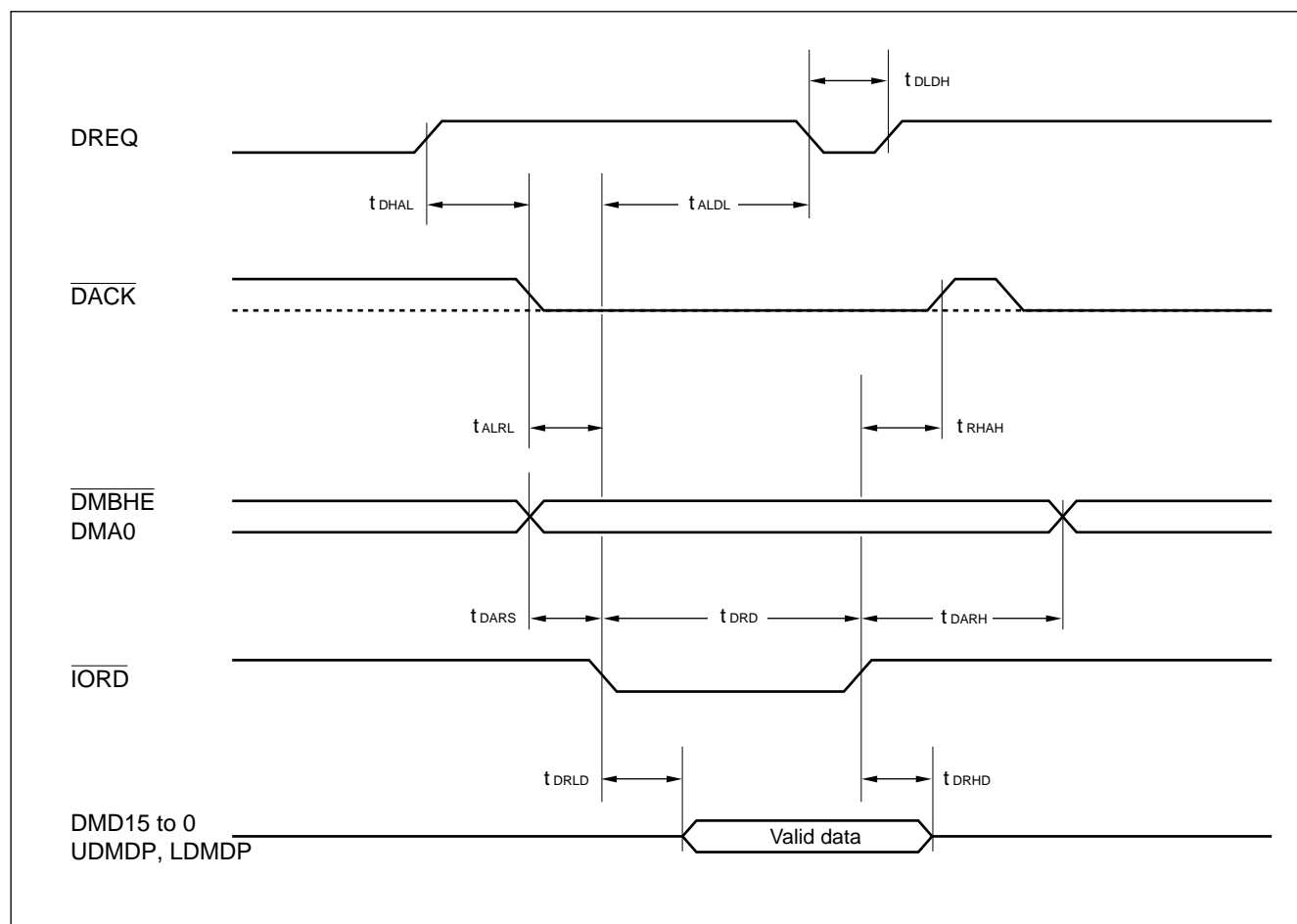

MB86606

(4) Write timing (burst mode for 68 series)

Parameter	Symbol	Value		Unit
		Min.	Max.	
DREQ set High → $\overline{\text{DACK}}$ set Low	t_{DHAL}	0	—	ns
$\overline{\text{DMUDS}}/\overline{\text{DMLDS}}$ set Low → DREQ set Low	t_{ALDL}	—	25	ns
DREQ set Low → DREQ set High	t_{DLDH}	0	—	ns
$\overline{\text{DACK}}$ set Low → $\overline{\text{DMUDS}}/\overline{\text{DMLDS}}$ set Low	t_{ALDL}	5	—	ns
$\text{R}/\overline{\text{W}}$ setup time	t_{DRWS}	10	—	ns
$\overline{\text{DMUDS}}/\overline{\text{DMLDS}}$ "L" level pulse width	t_{DDS}	25	—	ns
$\overline{\text{DMUDS}}/\overline{\text{DMLDS}}$ set High → $\overline{\text{DACK}}$ set High	t_{DHAH}	0	—	ns
$\text{R}/\overline{\text{W}}$ hold time	t_{DRWH}	10	—	ns
Input data setup time	t_{DDWS}	25	—	ns
Input data hold time	t_{DDWH}	5	—	ns

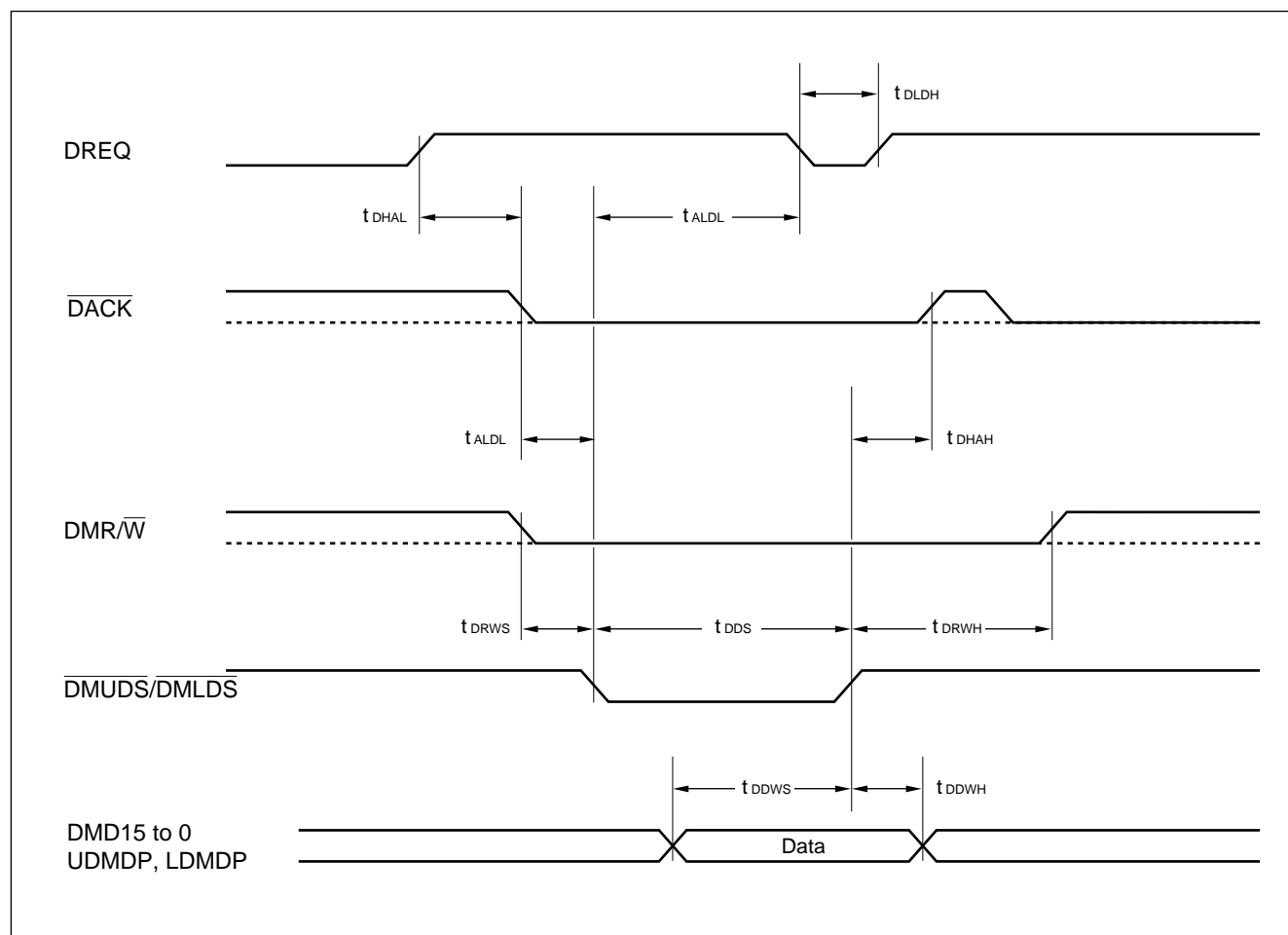

(5) Read timing (burst mode for 68 series)

Parameter	Symbol	Value		Unit
		Min.	Max.	
DREQ set High → $\overline{\text{DACK}}$ set Low	t_{DHAL}	0	—	ns
$\overline{\text{DMUDS}}/\overline{\text{DMLDS}}$ set Low → DREQ set Low	t_{ALDL}	—	25	ns
DREQ set Low → DREQ set High	t_{DLDH}	0	—	ns
$\overline{\text{DACK}}$ set Low → $\overline{\text{DMUDS}}/\overline{\text{DMLDS}}$ set Low	t_{ALDL}	5	—	ns
$\text{R}/\overline{\text{W}}$ setup time	t_{DRWS}	10	—	ns
$\overline{\text{DMUDS}}/\overline{\text{DMLDS}}$ "L" level pulse width	t_{DDS}	25	—	ns
$\overline{\text{DMUDS}}/\overline{\text{DMLDS}}$ set High → $\overline{\text{DACK}}$ set High	t_{DHAH}	0	—	ns
$\text{R}/\overline{\text{W}}$ hold time	t_{DRWH}	10	—	ns
Output data valid time	t_{DRLD}	—	25	ns
Output data hold time	t_{DRHD}	10	—	ns

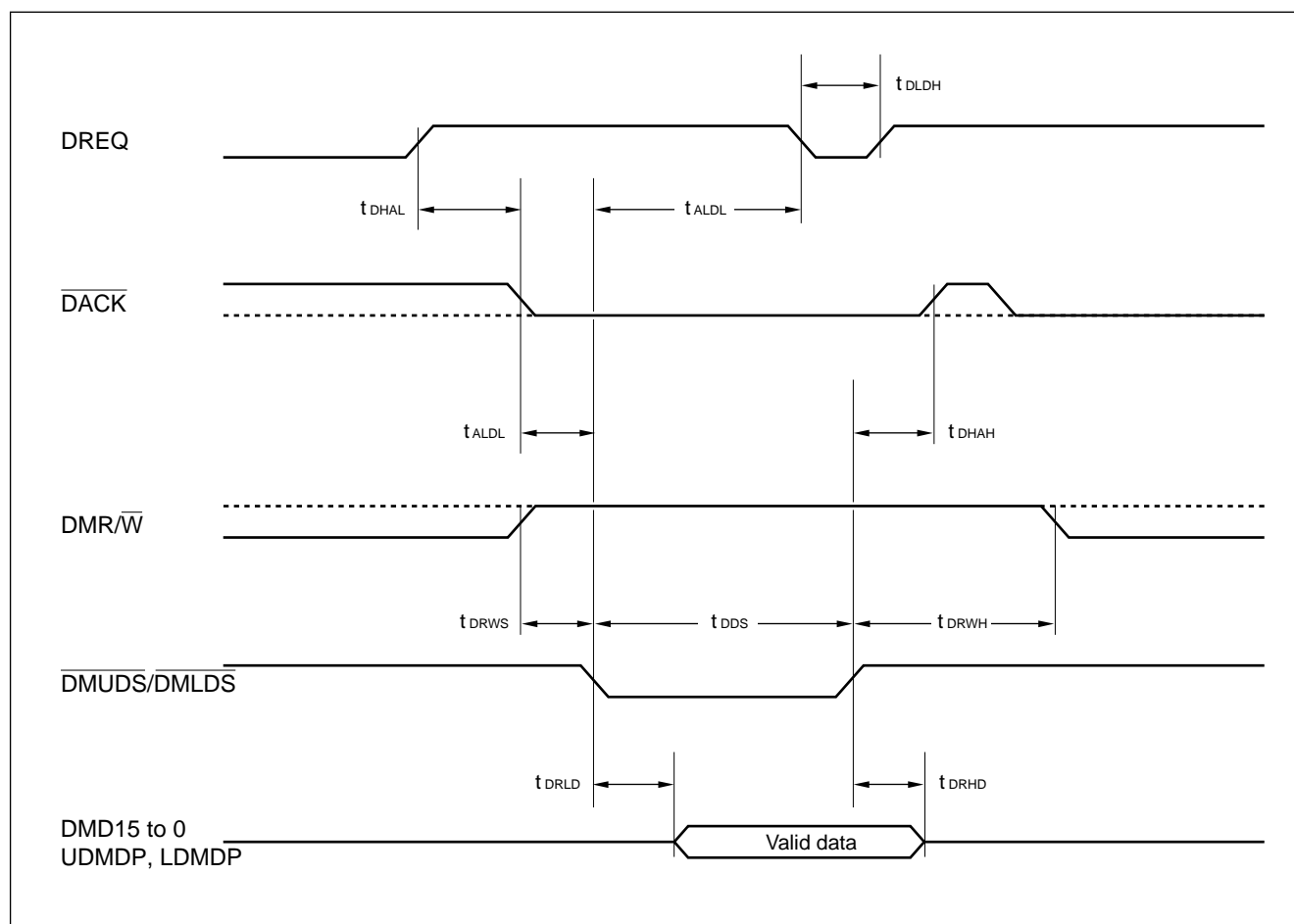

MB86606

7. PCI Interface

(1) PCI interface signal timing

Parameter	Symbol	Value		Unit
		Min.	Max.	
Output signal valid time	t_{PVAL}	2	11/12 ^{*1}	ns
Output disable time	t_{POFF}	—	28	ns
Output enable time	t_{PON}	2	—	ns
Input setup time	t_{PSU}	7/10 ^{*2}	—	ns
Input hold time	t_{PHD}	0	—	ns

*1: Applicable to \overline{PREQ} pin

*2: Applicable to \overline{GNT} pin

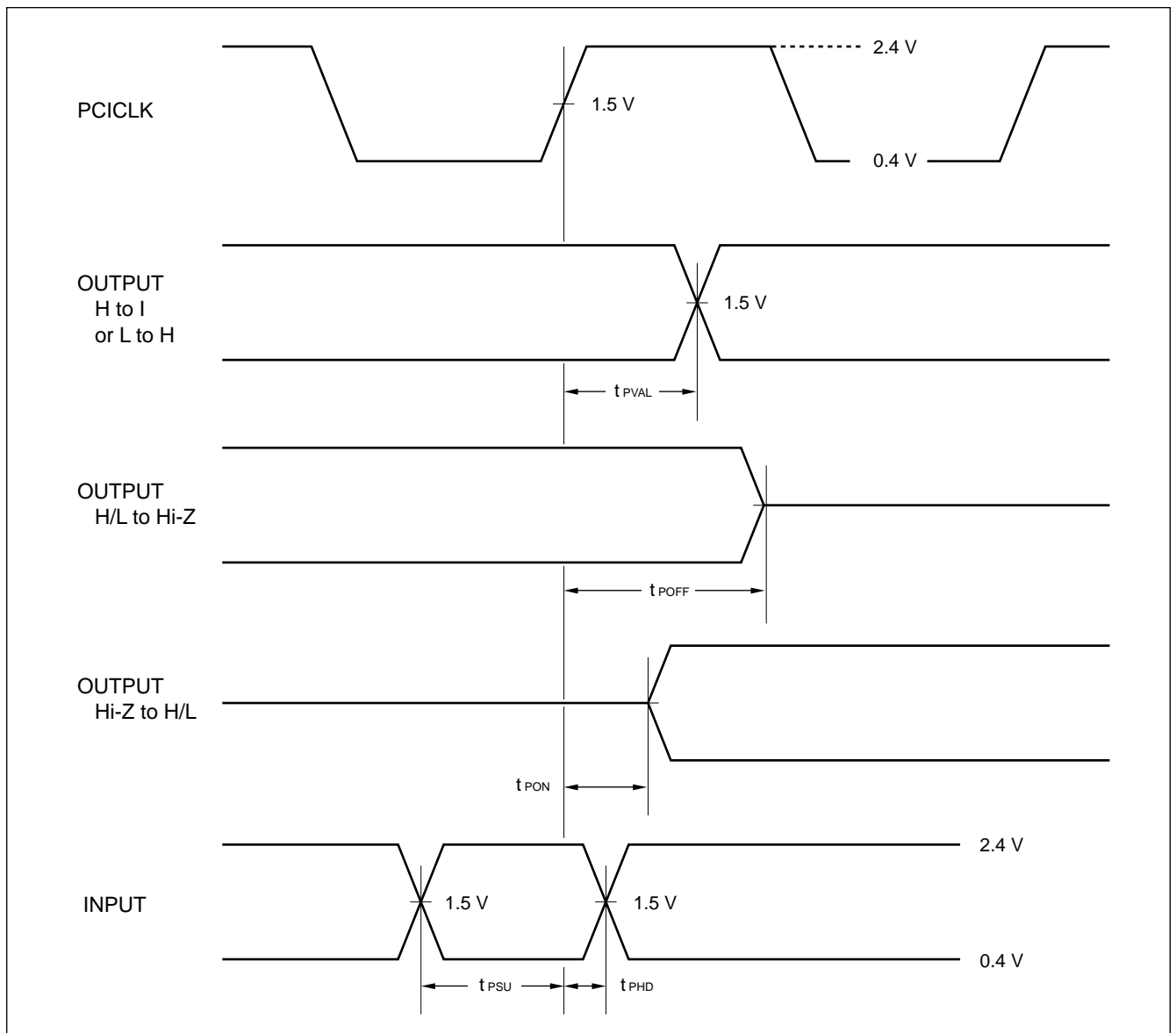

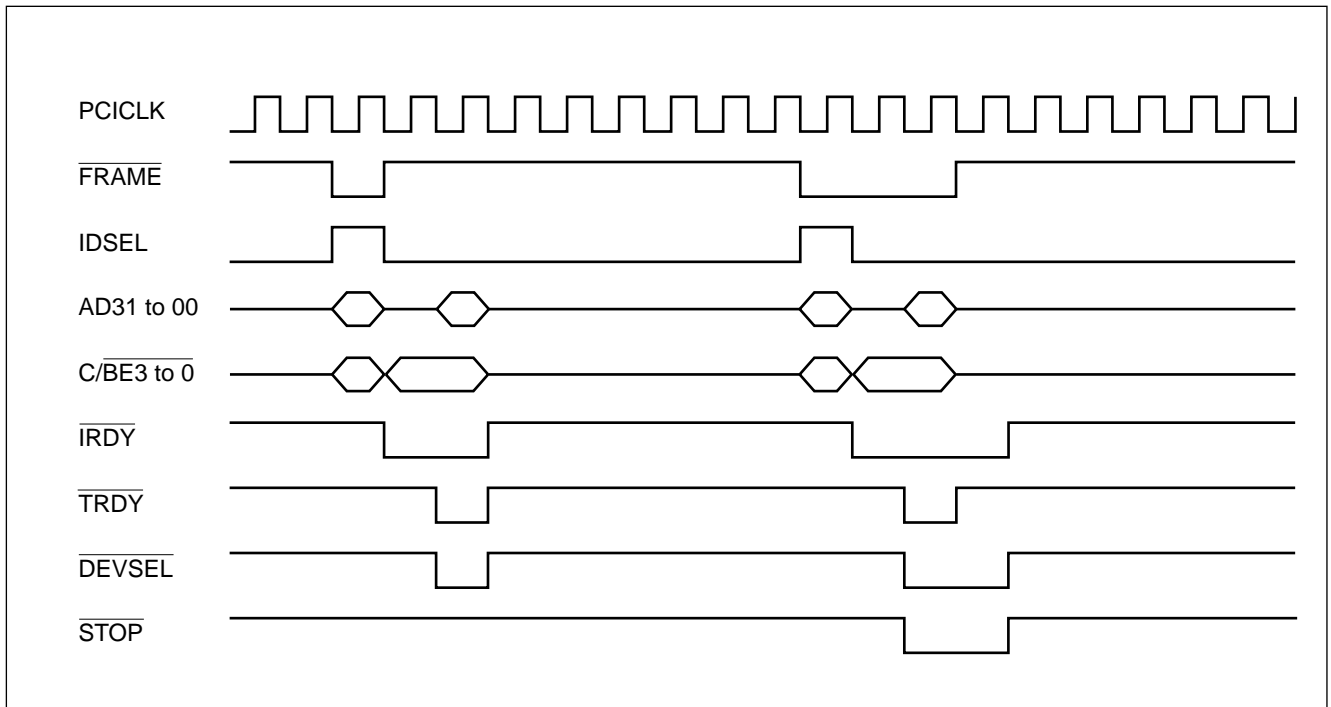
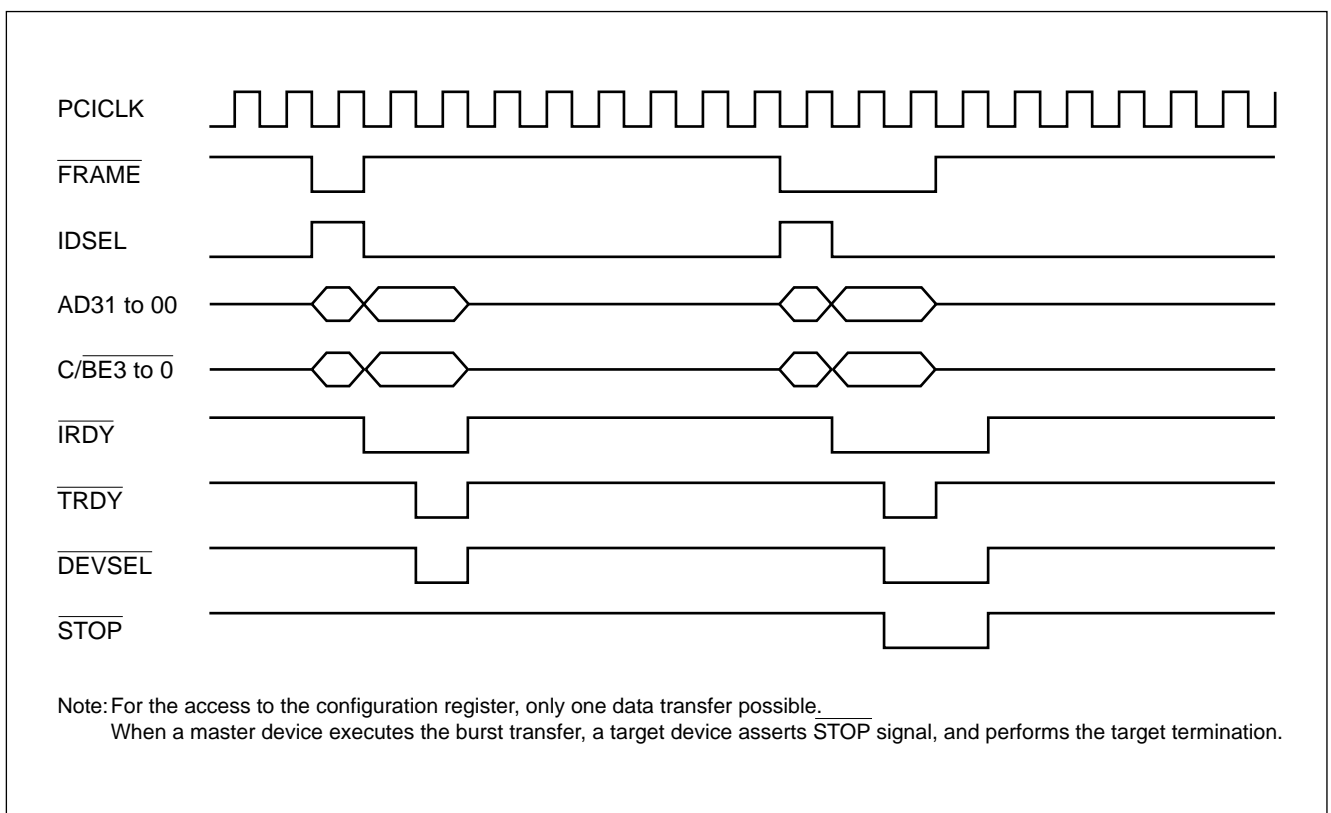
(2) Configuration register read timing**(3) Configuration register write timing**

MB86606

(4) BASIC control register read timing (target mode)

- Byte or word access

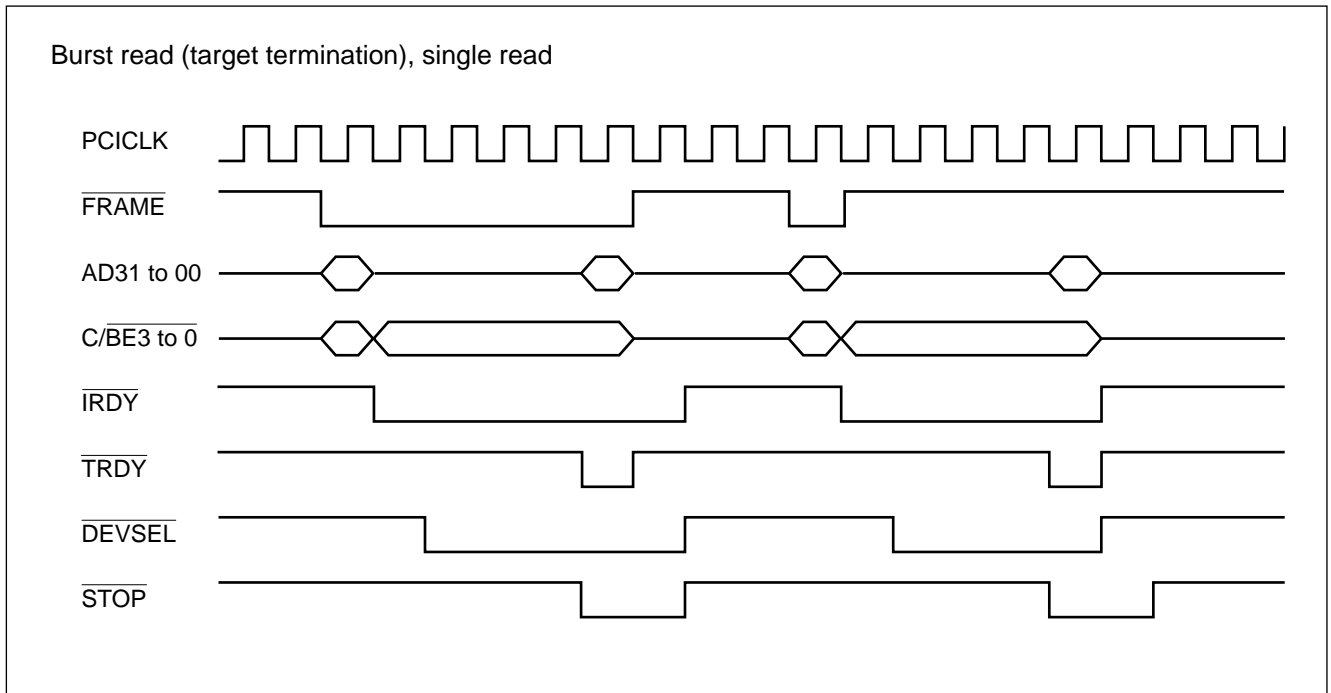

- Long-word access

Single read

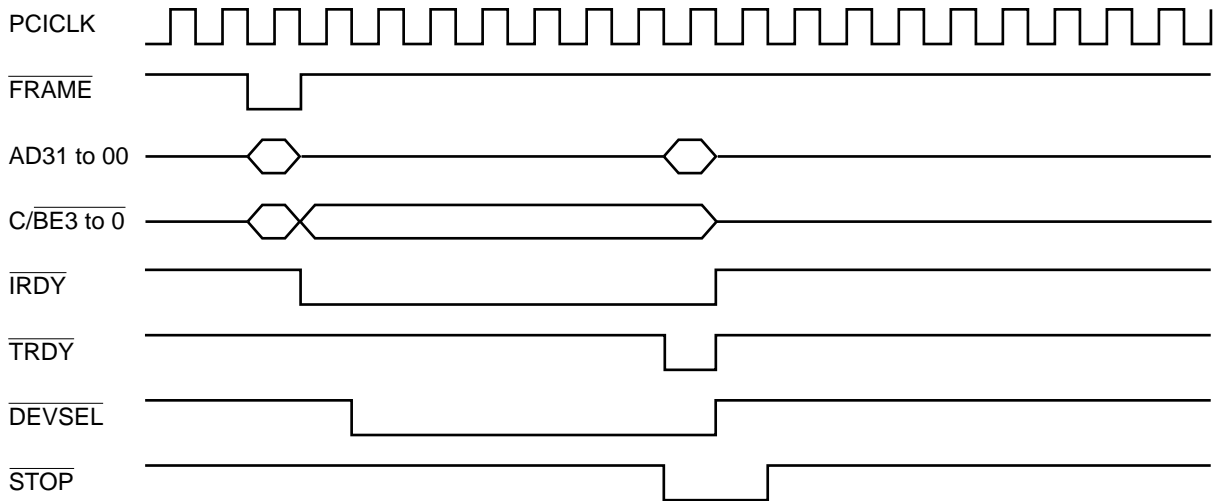

Burst read (target termination)

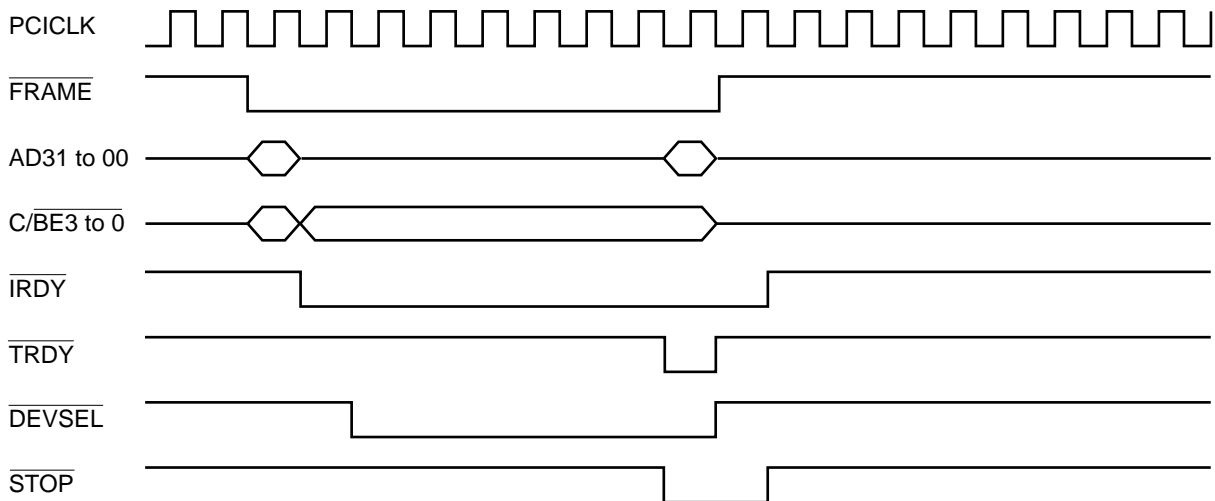

Note: For the read operation of BASIC control registers, only one data transfer possible.

When a master device executes the burst transfer, a target device asserts STOP signal and performs the target termination.

MB86606

(5) Target mode – I/O, memory read timing (except BASIC control registers)

- Byte, word access

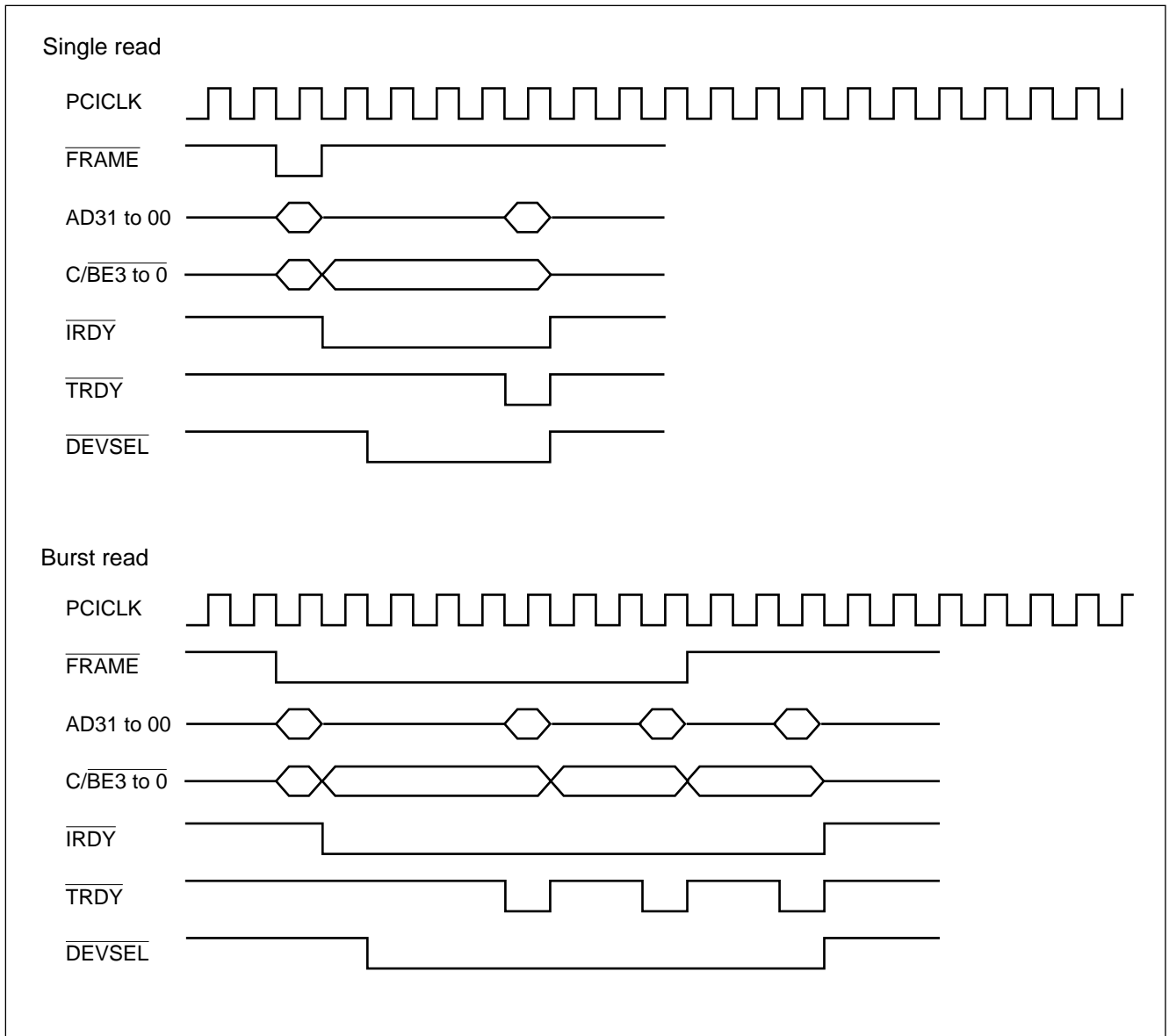

• Long-word access

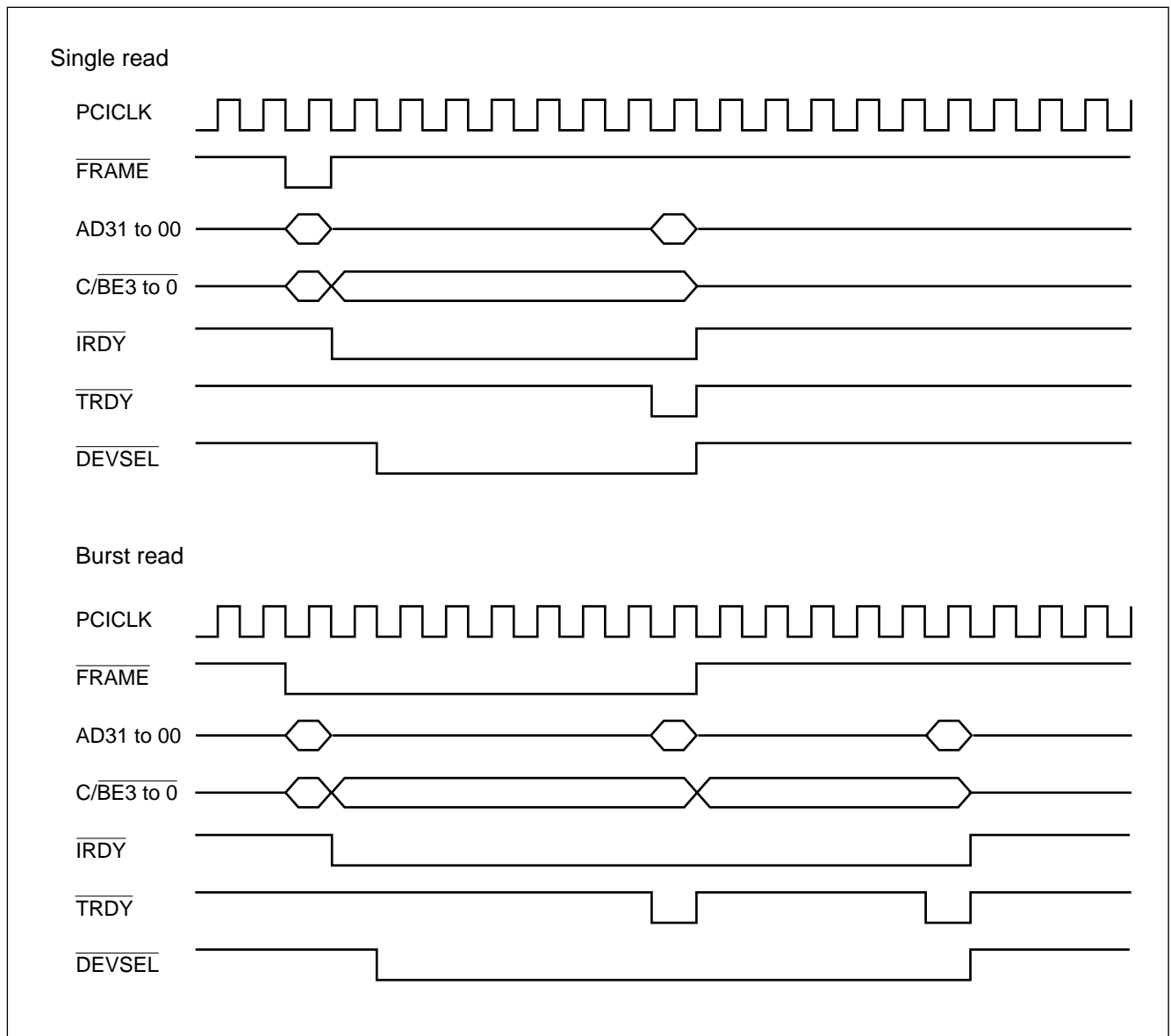

MB86606

(6) Target Mode – I/O, memory write timing

- Byte, word access

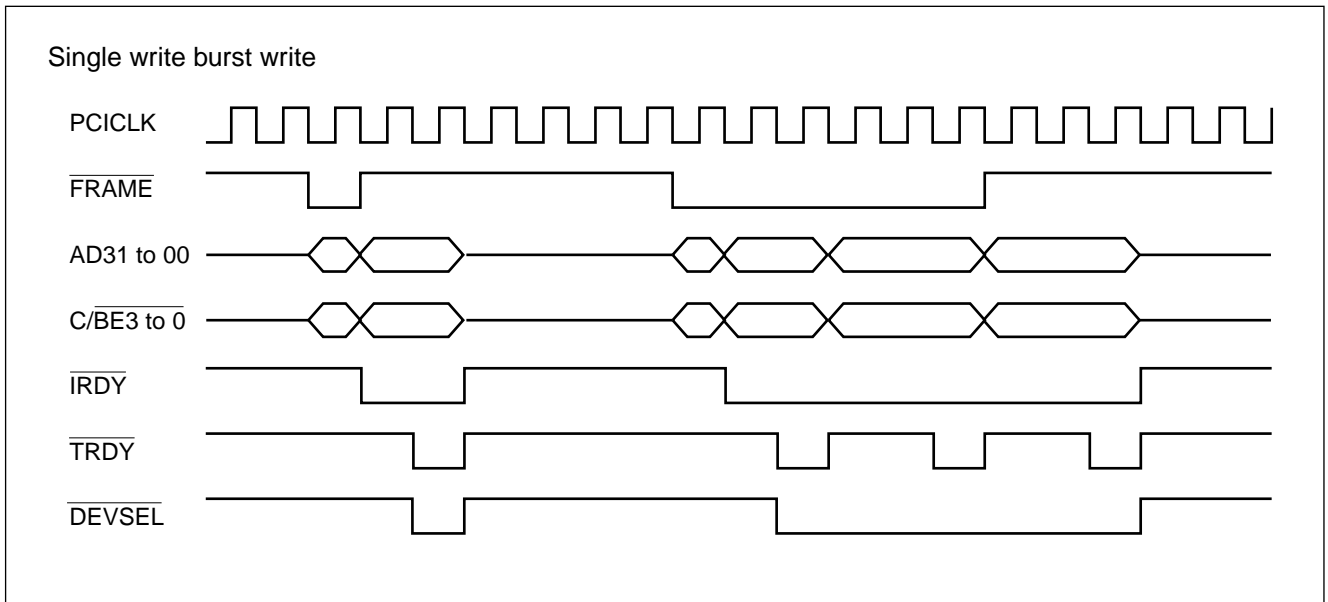

• Long-word access

Single write

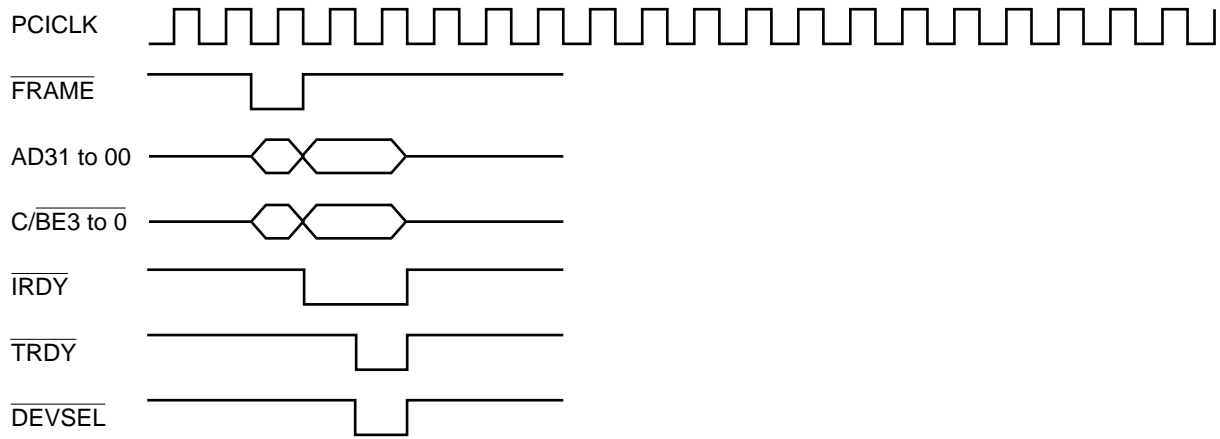

Burst write

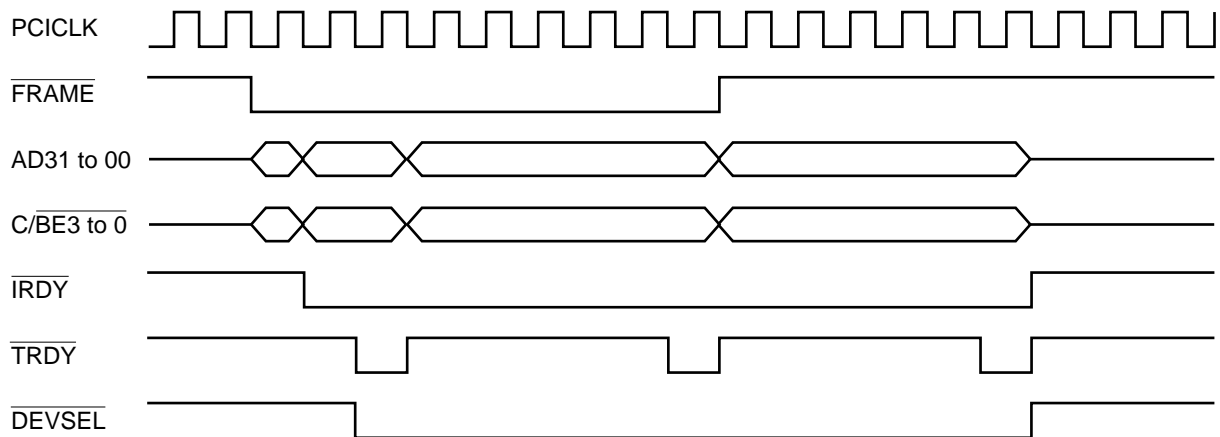

MB86606

(7) Data read timing (master mode)

• Burst length = 1 and 4

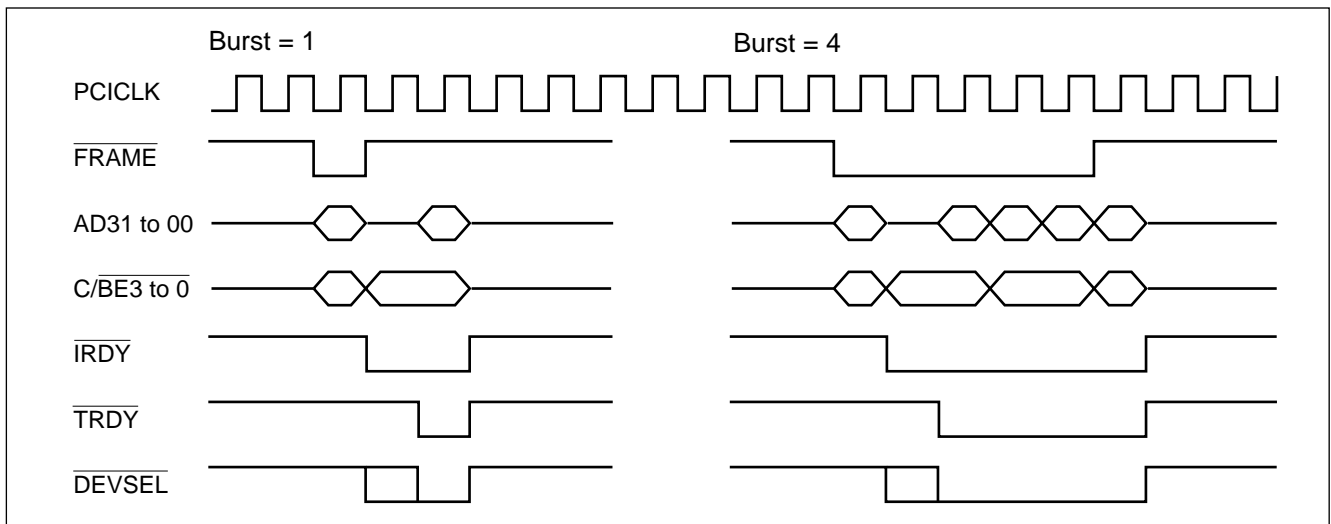

• Burst length = 8

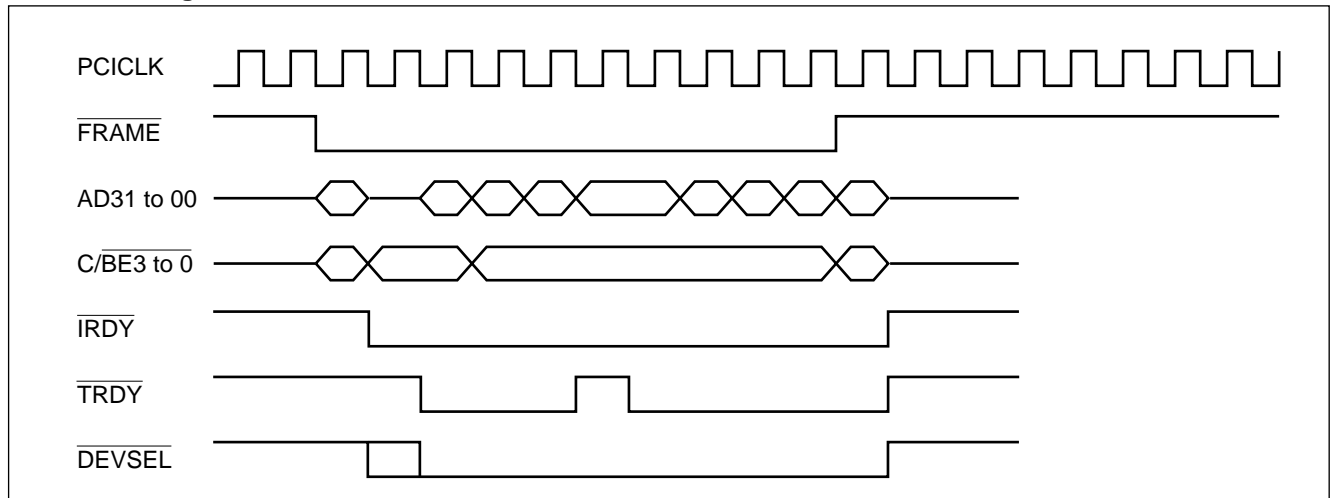

• Burst length = 16

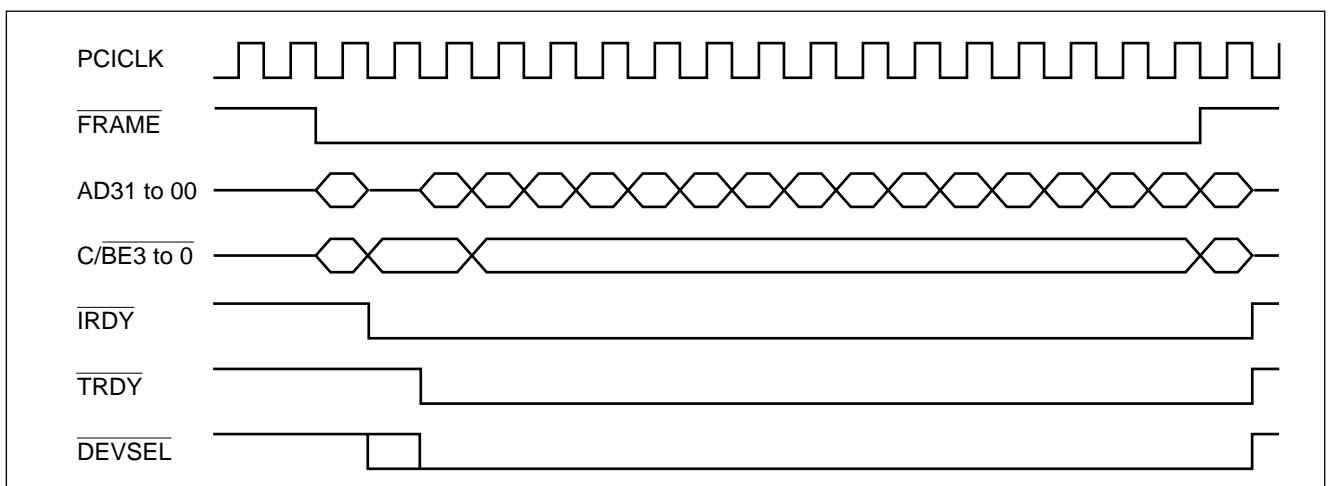

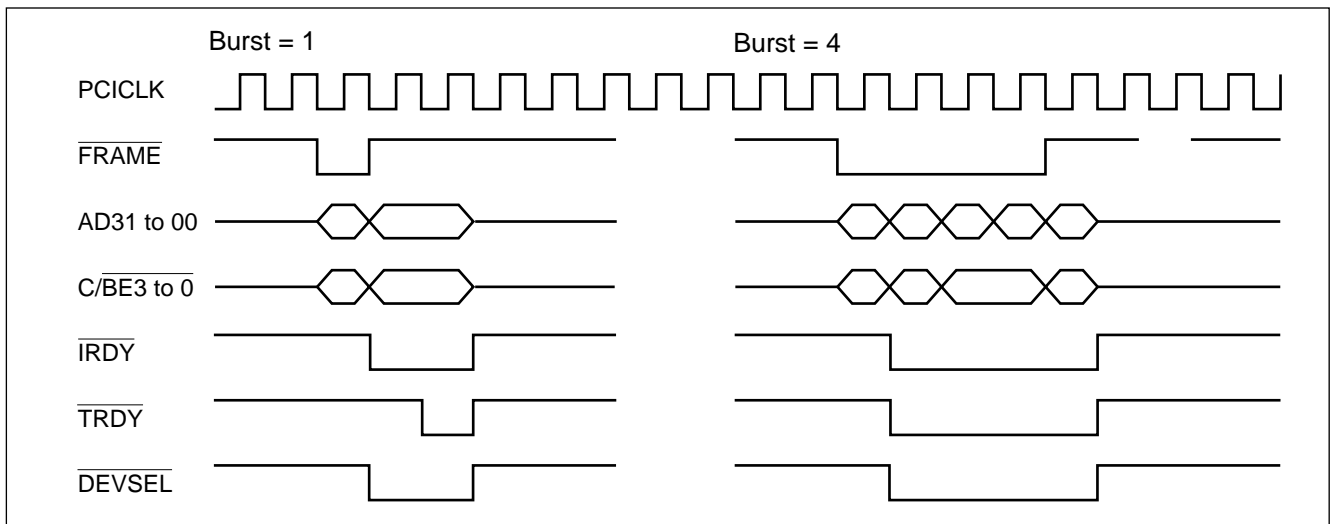
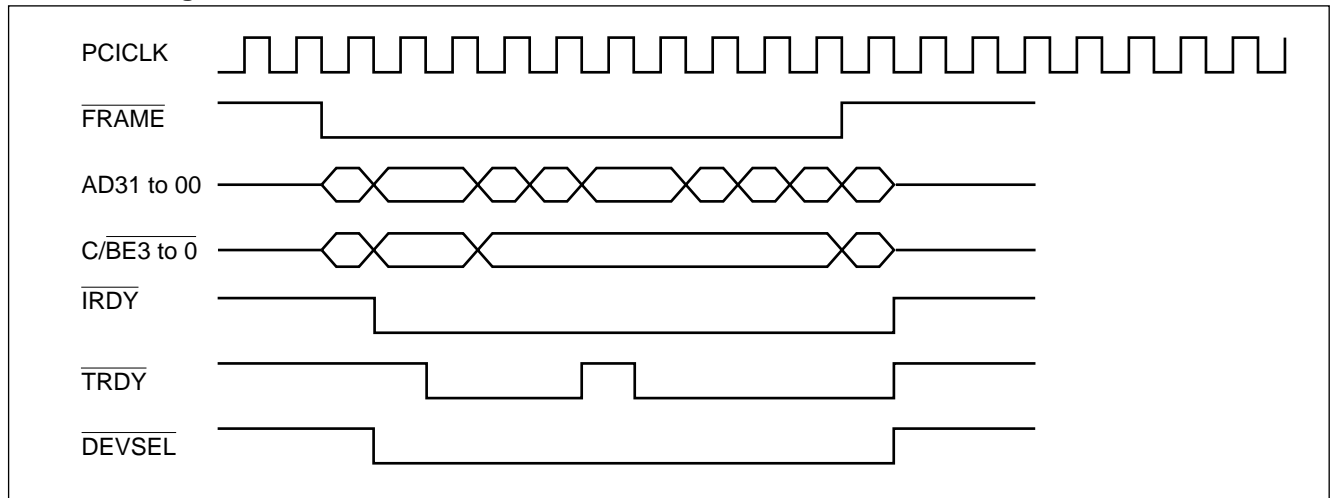
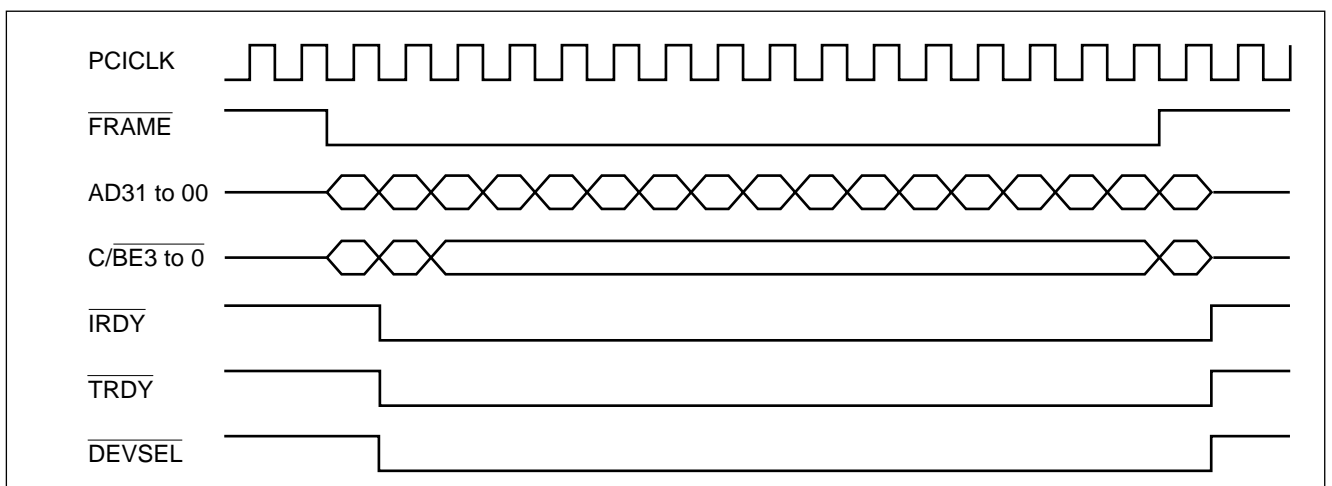
(8) Data write timing (master mode)**• Burst length = 1 and 4****• Burst length = 8****• Burst length = 16**

MB86606

8. SCSI Interface

(1) Initiator asynchronous input timing (target → initiator)

Parameter	Symbol	Value		Unit
		Min.	Max.	
\overline{ACK} set Low → \overline{REQ} set High	tAOLR	0	—	ns
\overline{REQ} set High → \overline{ACK} set High	tRAOH	—	60	ns
\overline{ACK} set High → \overline{REQ} set Low	tAOHR	10	—	ns
Data bus valid → \overline{REQ} set Low	tDTSU	10	—	ns
\overline{REQ} set Low → data bus hold time	tDHLD	20	—	ns
\overline{REQ} set Low → \overline{ACK} set Low	tRAOL	—	40	ns
\overline{REQ} set High → \overline{ACK} set Low*	tRACY	—	3 tCLF + 40	ns

* : tRACY (\overline{REQ} set High → \overline{ACK} set Low) is defined as either longer time of (tRAOH + tAOHR + tRAOL) or tRACY itself

Note: Time requirements in this section do not apply in the following cases;

- When data register FULL in data phase
- When last byte transferred

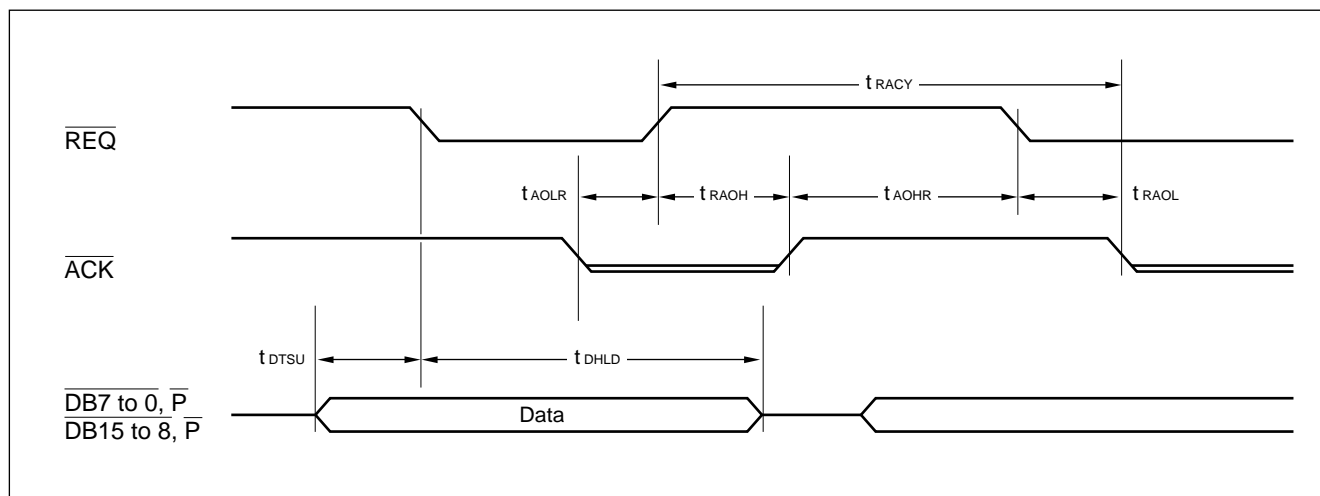

(2) Initiator asynchronous output timing (initiator → target)

Parameter	Symbol	Value		Unit
		Min.	Max.	
$\overline{\text{ACK}}$ set Low → $\overline{\text{REQ}}$ set High	t_{AOLR}	0	—	ns
$\overline{\text{REQ}}$ set High → $\overline{\text{ACK}}$ set High	t_{RAOH}	—	60	ns
$\overline{\text{ACK}}$ set High → $\overline{\text{REQ}}$ set Low	t_{AOHR}	10	—	ns
Data bus output defined → $\overline{\text{ACK}}$ set Low*	t_{DVLD}	$S \cdot t_{\text{CLF}} - 10$	—	ns
$\overline{\text{REQ}}$ set High → data bus hold time	t_{DIVD}	$2 t_{\text{CLF}}$	—	ns
$\overline{\text{REQ}}$ set Low → $\overline{\text{ACK}}$ set Low	t_{RAOL}	—	40	ns

* : The value of S varies with the setting condition of the asynchronous setup time register (address 17h).

Note: This output timing regulations are not applicable when the data register is EMPTY in the data phase.

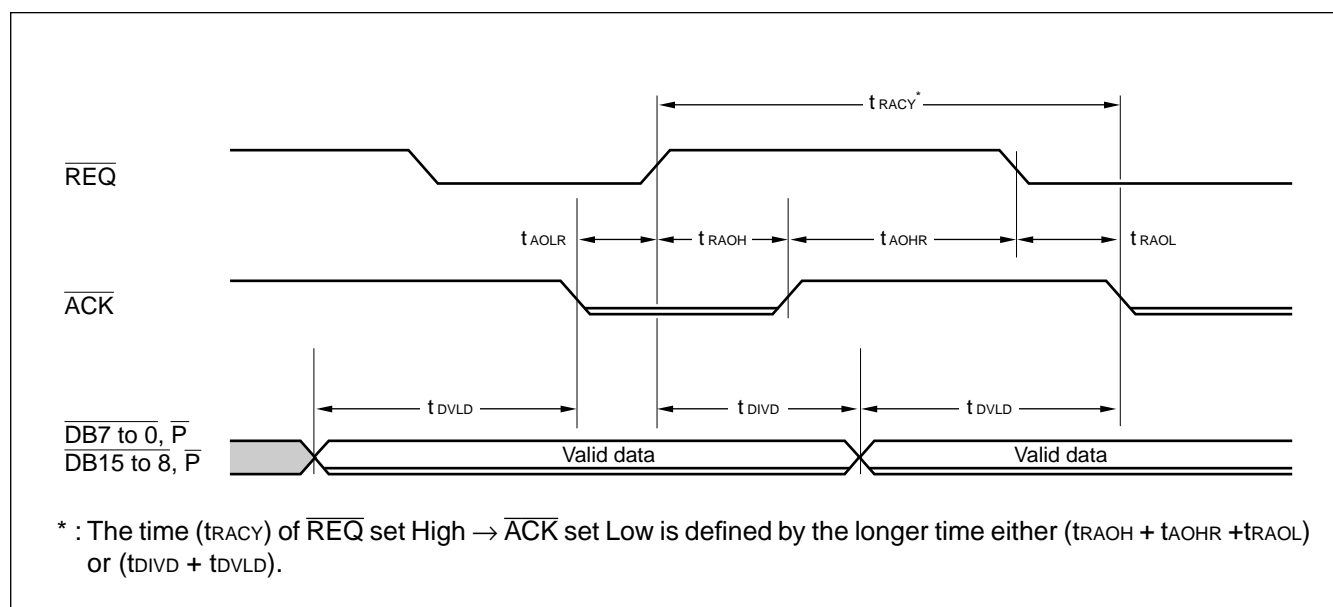

MB86606

(3) Initiator synchronous transfer $\overline{\text{REQ}}/\overline{\text{ACK}}$ timing

Parameter	Symbol	Value		Unit
		Min.	Max.	
$\overline{\text{ACK}}$ Assertion Period*	t_{AKAP}	$A \cdot t_{\text{CLF}} - 4$	—	ns
$\overline{\text{ACK}}$ Negation Period*	t_{ANAP}	$N \cdot t_{\text{CLF}} - 6$	—	ns
$\overline{\text{REQ}}$ Assertion Period	t_{RQAP}	20	—	ns
$\overline{\text{REQ}}$ Negation Period	t_{RNAP}	20	—	ns
$\overline{\text{REQ}}$ input cycle time (1)	t_{RQF1}	1 tCLF	—	ns
$\overline{\text{REQ}}$ input cycle time (2)	t_{RQF2}	3 tCLF	—	ns

* : The values of A and N vary with the setting condition of the transfer period register (address 0Ch).

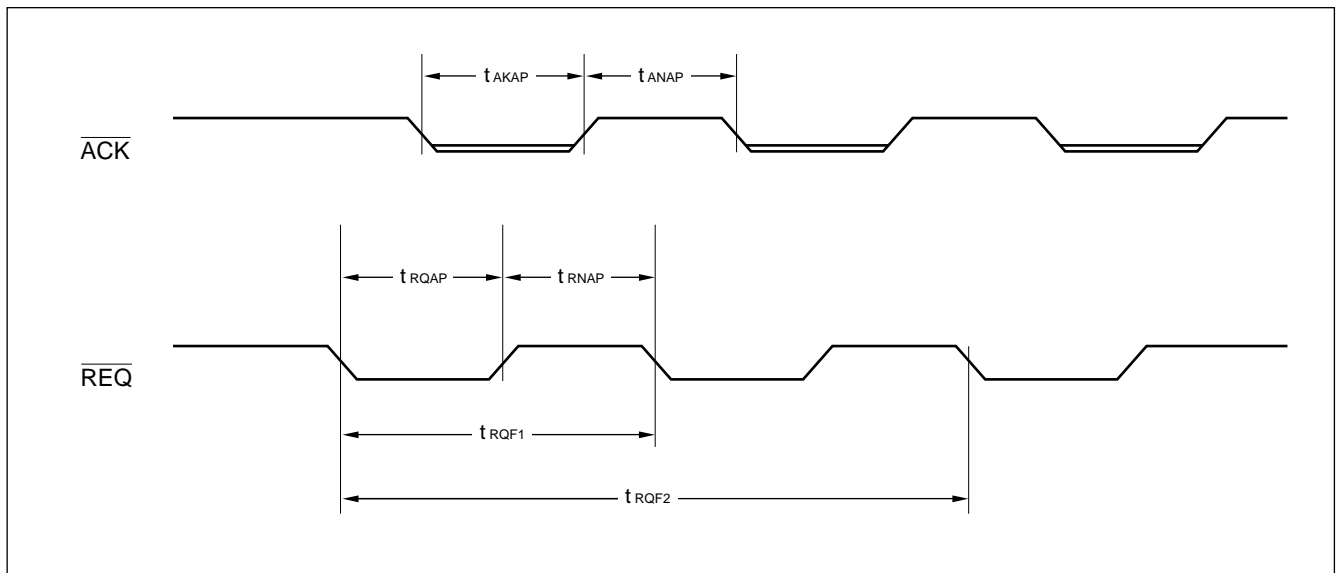

(4) Initiator synchronous transfer input timing (target → initiator)

Parameter	Symbol	Value		Unit
		Min.	Max.	
Data bus defined → $\overline{\text{REQ}}$ set Low	tDTSU	5	—	ns
$\overline{\text{REQ}}$ set Low → data bus hold time	tDHLD	15	—	ns

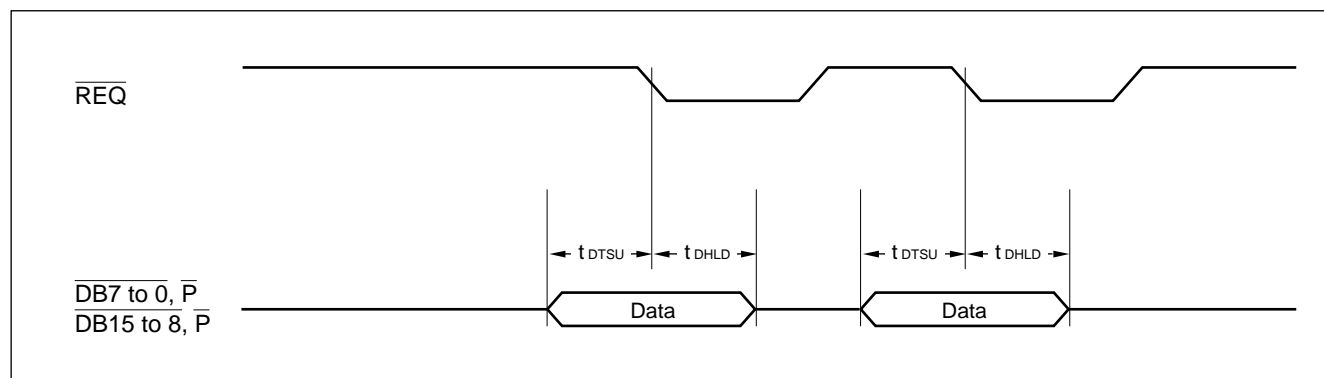

(5) Initiator synchronous transfer output timing (initiator → target)

Parameter	Symbol	Value		Unit
		Min.	Max.	
Data bus defined → $\overline{\text{ACK}}$ set Low*	tDVAK	$N \cdot t_{\text{CLF}} - 10$	—	ns
$\overline{\text{ACK}}$ set Low → data bus hold time*	tAKDH	$A \cdot t_{\text{CLF}} - 5$	—	ns

* : The values of A and N vary with the setting condition of the transfer period register (address 0Ch).

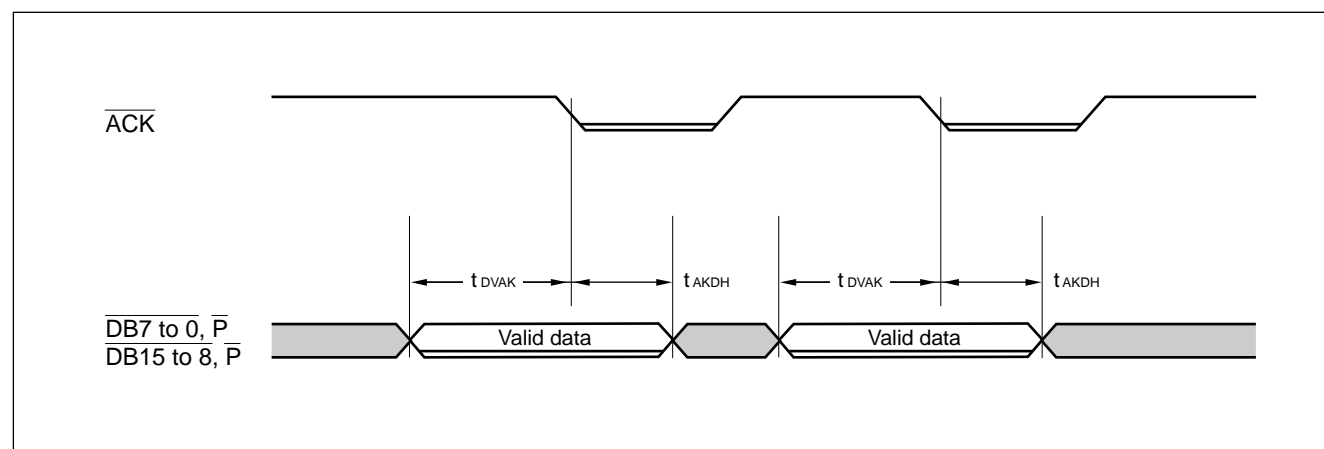

MB86606

(6) Target asynchronous input timing (initiator → target)

Parameter	Symbol	Value		Unit
		Min.	Max.	
$\overline{\text{REQ}}$ set Low → $\overline{\text{ACK}}$ set Low	t_{ROLA}	0	—	ns
$\overline{\text{ACK}}$ set Low → $\overline{\text{REQ}}$ set High	t_{AROH}	—	60	ns
$\overline{\text{REQ}}$ set High → $\overline{\text{ACK}}$ set High	t_{ROHA}	0	—	ns
Data bus defined → $\overline{\text{ACK}}$ set Low	t_{DTSU}	10	—	ns
$\overline{\text{ACK}}$ set Low → data bus hold time	t_{DHLD}	20	—	ns
$\overline{\text{ACK}}$ set High → $\overline{\text{REQ}}$ set Low	t_{AROL}	—	40	ns
$\overline{\text{ACK}}$ set Low → $\overline{\text{REQ}}$ set Low*	t_{RACY}	—	$3 t_{\text{CLF}} + 40$	ns

* : t_{RACY} ($\overline{\text{ACK}}$ set Low → $\overline{\text{REQ}}$ set Low) is defined as either longer time of ($t_{\text{AROH}} + t_{\text{ROHA}} + t_{\text{AROL}}$) or t_{RACY} itself

Note: The input timing regulations are not applicable when the data register is FULL in the data phase.

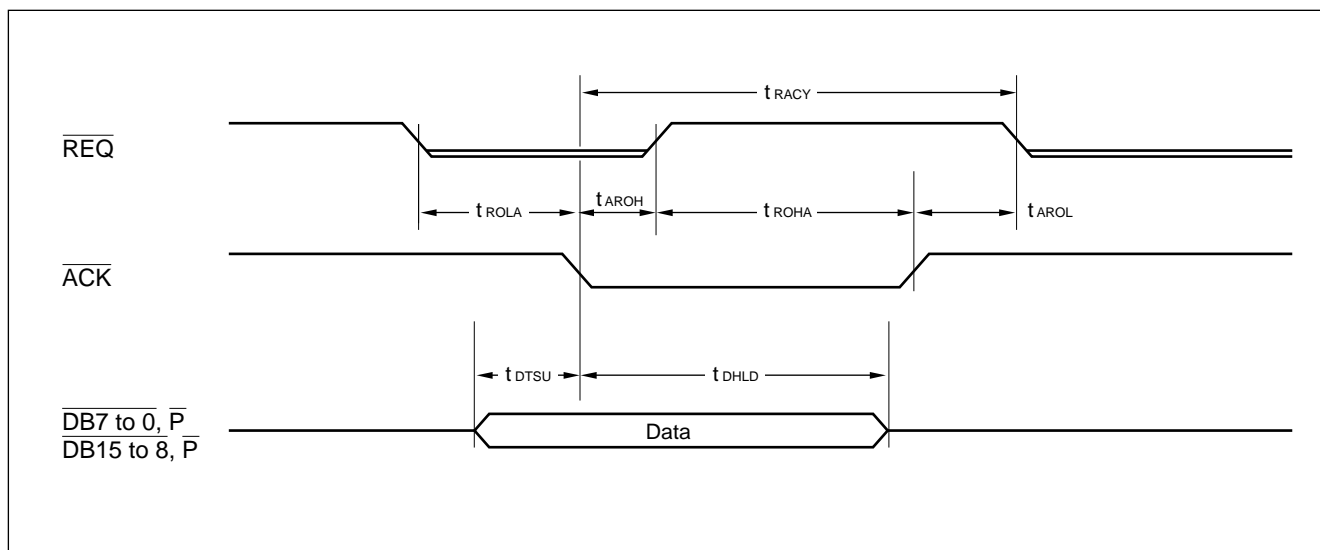

(7) Target asynchronous input timing (target → initiator)

Parameter	Symbol	Value		Unit
		Min.	Max.	
$\overline{\text{REQ}}$ set Low → $\overline{\text{ACK}}$ set Low	t_{ROLA}	0	—	ns
$\overline{\text{ACK}}$ set Low → $\overline{\text{REQ}}$ set High	t_{AROH}	—	60	ns
$\overline{\text{REQ}}$ set High → $\overline{\text{ACK}}$ set High	t_{ROHA}	0	—	ns
Data bus defined → $\overline{\text{REQ}}$ set Low*	t_{DVLD}	$S \cdot t_{\text{CLF}} - 10$	—	ns
$\overline{\text{ACK}}$ set Low → data bus hold time	t_{DIVD}	$2 t_{\text{CLF}}$	—	ns
$\overline{\text{ACK}}$ set High → $\overline{\text{REQ}}$ set Low	t_{AROL}	—	40	ns

* : The value of S varies with the setting condition of the asynchronous setup time register (address 17h).

Note: The output timing regulations are not applicable when the data register is EMPTY in the data phase.

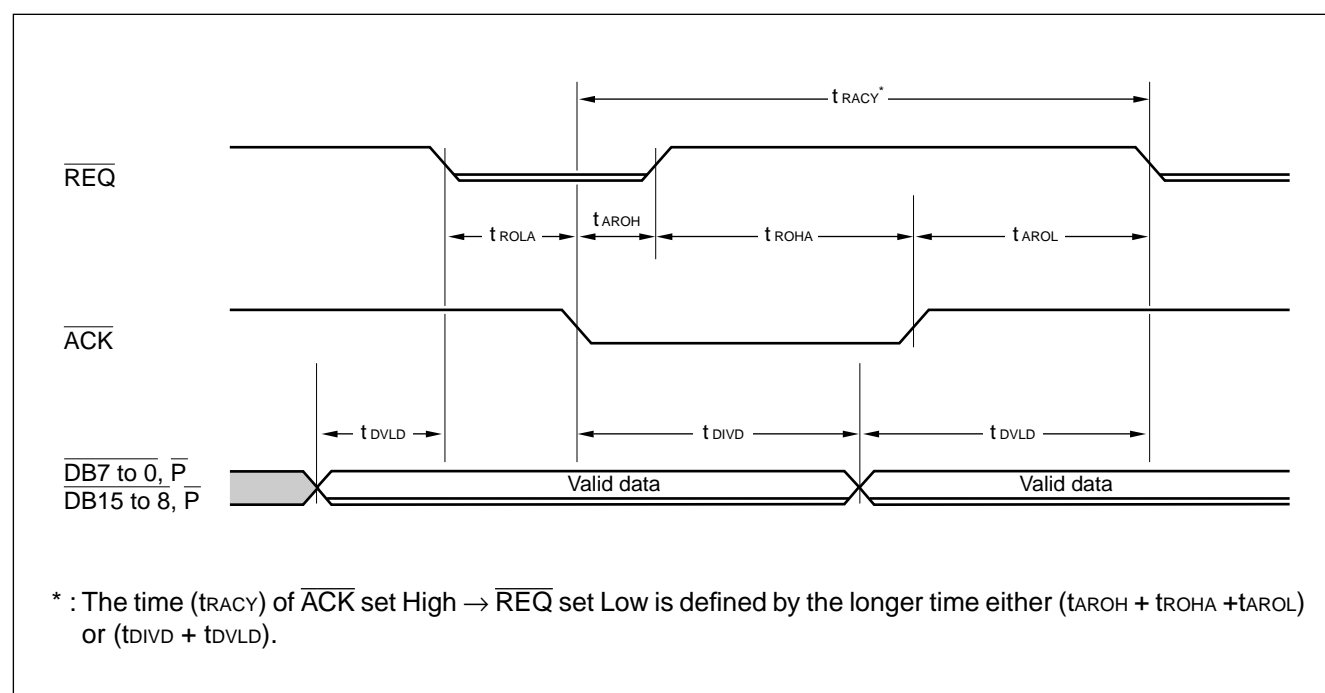

MB86606

(8) Target synchronous transfer $\overline{\text{REQ}}/\overline{\text{ACK}}$ timing

Parameter	Symbol	Value		Unit
		Min.	Max.	
$\overline{\text{REQ}}$ Assertion Period*	t_{RQAP}	$A \cdot t_{\text{CLF}} - 4$	—	ns
$\overline{\text{REQ}}$ Negation Period*	t_{RNAP}	$N \cdot t_{\text{CLF}} - 6$	—	ns
$\overline{\text{ACK}}$ Assertion Period	t_{AKAP}	20	—	ns
$\overline{\text{ACK}}$ Negation Period	t_{ANAP}	20	—	ns
$\overline{\text{ACK}}$ input cycle time (1)	t_{AKF1}	1 tCLF	—	ns
$\overline{\text{ACK}}$ input cycle time (2)	t_{AKF2}	3 tCLF	—	ns

* : The values of A and N vary with the setting condition of the transfer period register (address 0Ch).

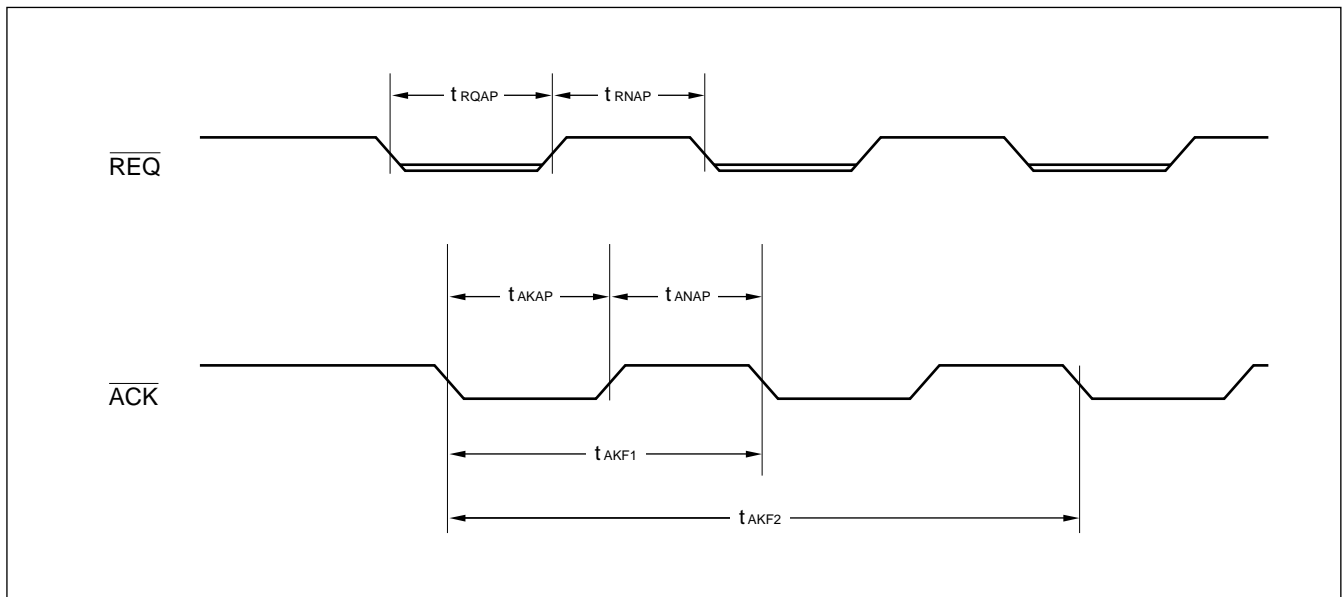

(9) Target synchronous transfer input timing (initiator → target)

Parameter	Symbol	Value		Unit
		Min.	Max.	
Data bus defined → $\overline{\text{ACK}}$ set Low	tDTSU	5	—	ns
$\overline{\text{ACK}}$ set Low → data bus hold time	tDHL D	15	—	ns

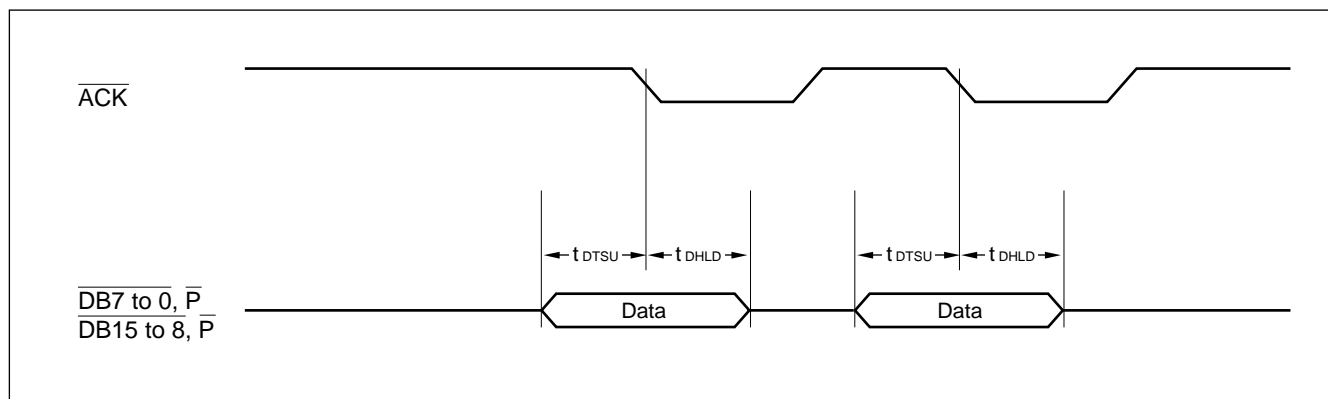

(10) Target synchronous transfer output timing (target → initiator)

Parameter	Symbol	Value		Unit
		Min.	Max.	
Data bus defined → $\overline{\text{REQ}}$ set Low*	tDVRQ	$N \cdot t_{\text{CLF}} - 10$	—	ns
$\overline{\text{REQ}}$ set Low → data bus hold time*	tRQDH	$A \cdot t_{\text{CLF}} - 5$	—	ns

* : The values of A and N vary with the setting condition of the transfer period register (address 0Ch).

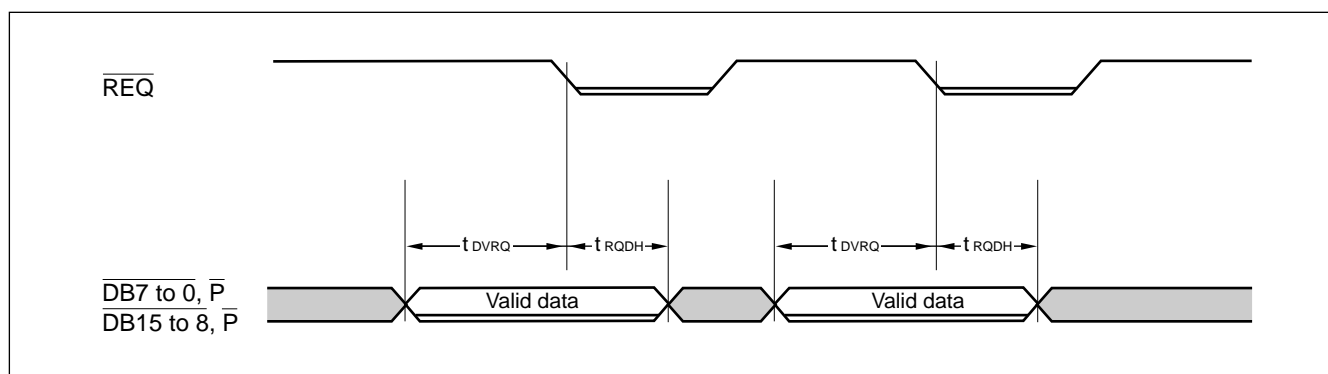

MB86606

(11) A, N, and S values in SCSI interface timing specifications

• Set value for transfer period register and A, N values

Transfer period register					A	N	Transfer period register					A	N
4	3	2	1	0			4	3	2	1	0		
0	0	0	0	1	(inhibited)	(inhibited)	1	0	0	0	1	9	8
0	0	0	1	0	1	1	1	0	0	1	0	9	9
0	0	0	1	1	2	1	1	0	0	1	1	10	9
0	0	1	0	0	2	2	1	0	1	0	0	10	10
0	0	1	0	1	3	2	1	0	1	0	1	11	10
0	0	1	1	0	3	3	1	0	1	1	0	11	11
0	0	1	1	1	4	3	1	0	1	1	1	12	11
0	1	0	0	0	4	4	1	1	0	0	0	12	12
0	1	0	0	1	5	4	1	1	0	0	1	13	12
0	1	0	1	0	5	5	1	1	0	1	0	13	13
0	1	0	1	1	6	5	1	1	0	1	1	14	13
0	1	1	0	0	6	6	1	1	1	0	0	14	14
0	1	1	0	1	7	6	1	1	1	0	1	15	14
0	1	1	1	0	7	7	1	1	1	1	0	15	15
0	1	1	1	1	8	7	1	1	1	1	1	16	15
1	0	0	0	0	8	8	0	0	0	0	0	16	16

Note: The A and N values in the register setting represent the assertion and negation periods (in clock-cycle units). The numerical value is applicable to the A and N values in AC characteristics.

- Set value for asynchronous setup time register and S value

Asynchronous setup time setting register				S
3	2	1	0	
0	0	0	1	1
0	0	1	0	2
0	0	1	1	3
0	1	0	0	4
0	1	0	1	5
0	1	1	0	6
0	1	1	1	7
1	0	0	0	8
1	0	0	1	9
1	0	1	0	10
1	0	1	1	11
1	1	0	0	12
1	1	0	1	13
1	1	1	0	14
1	1	1	1	15
0	0	0	0	16

Note: The S (setup time) value of the setup time setting register in asynchronous data transfer represents the time required to assert the $\overline{\text{REQ}}$ or $\overline{\text{ACK}}$ signal after setting data at the data bus (in clock-cycle units). The numerical value is applicable to the S value in AC characteristics.

MB86606

SYSTEM CONFIGURATION

1. 80-Series Separate Bus Type

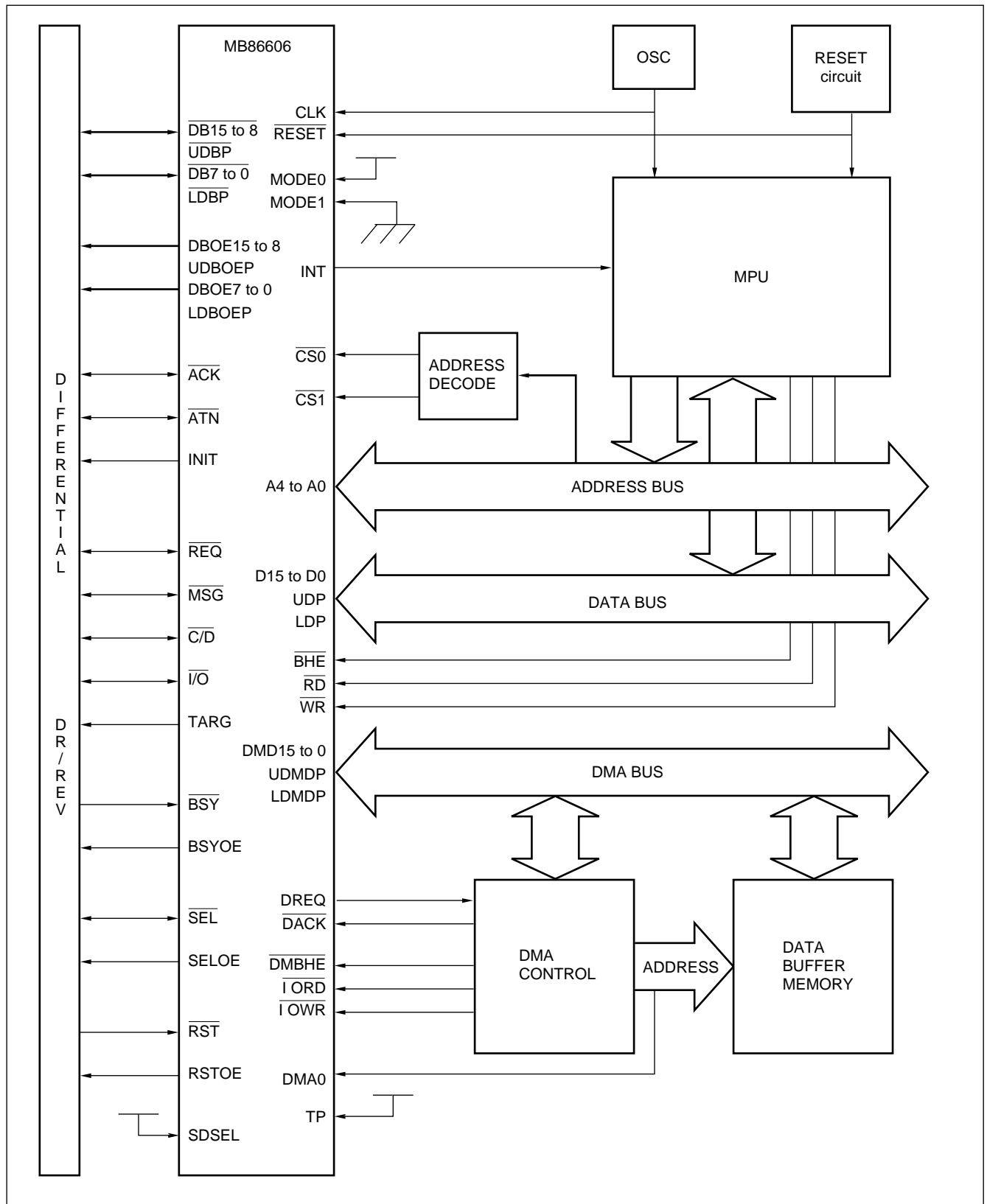

2. 68-Series Separate Bus Type

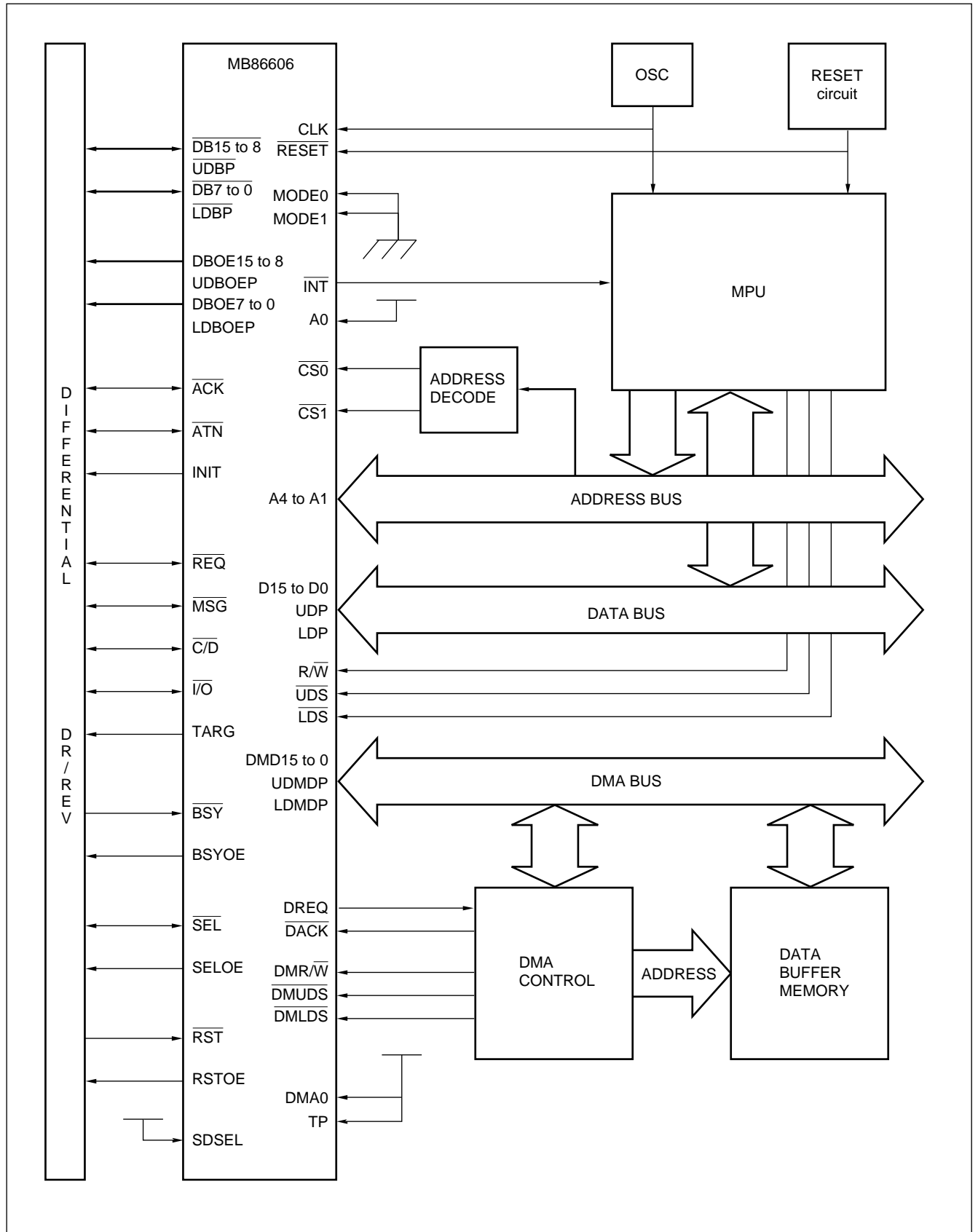

MB86606

3. 80-Series Common Bus Type

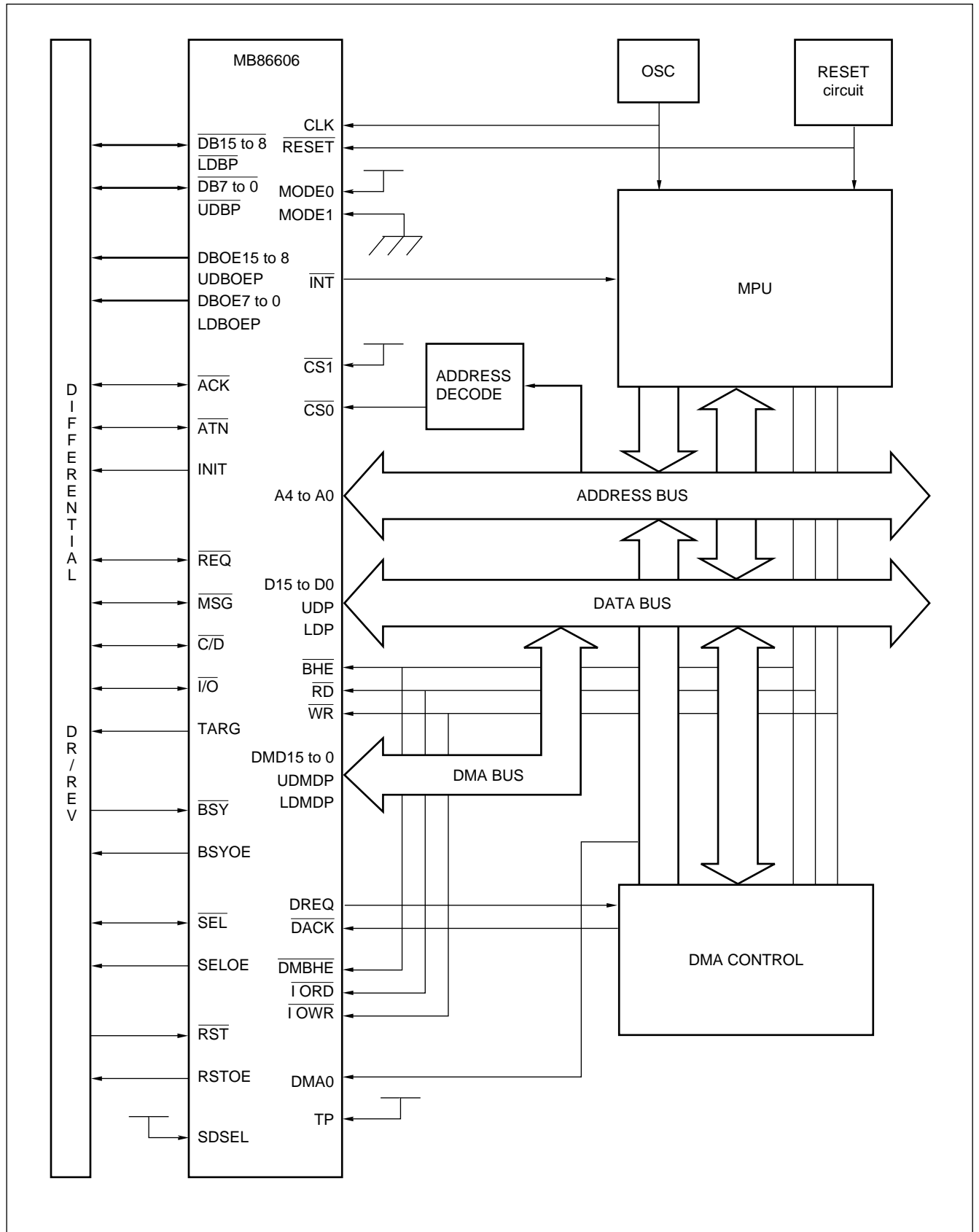

4. 68-Series Common Bus Type

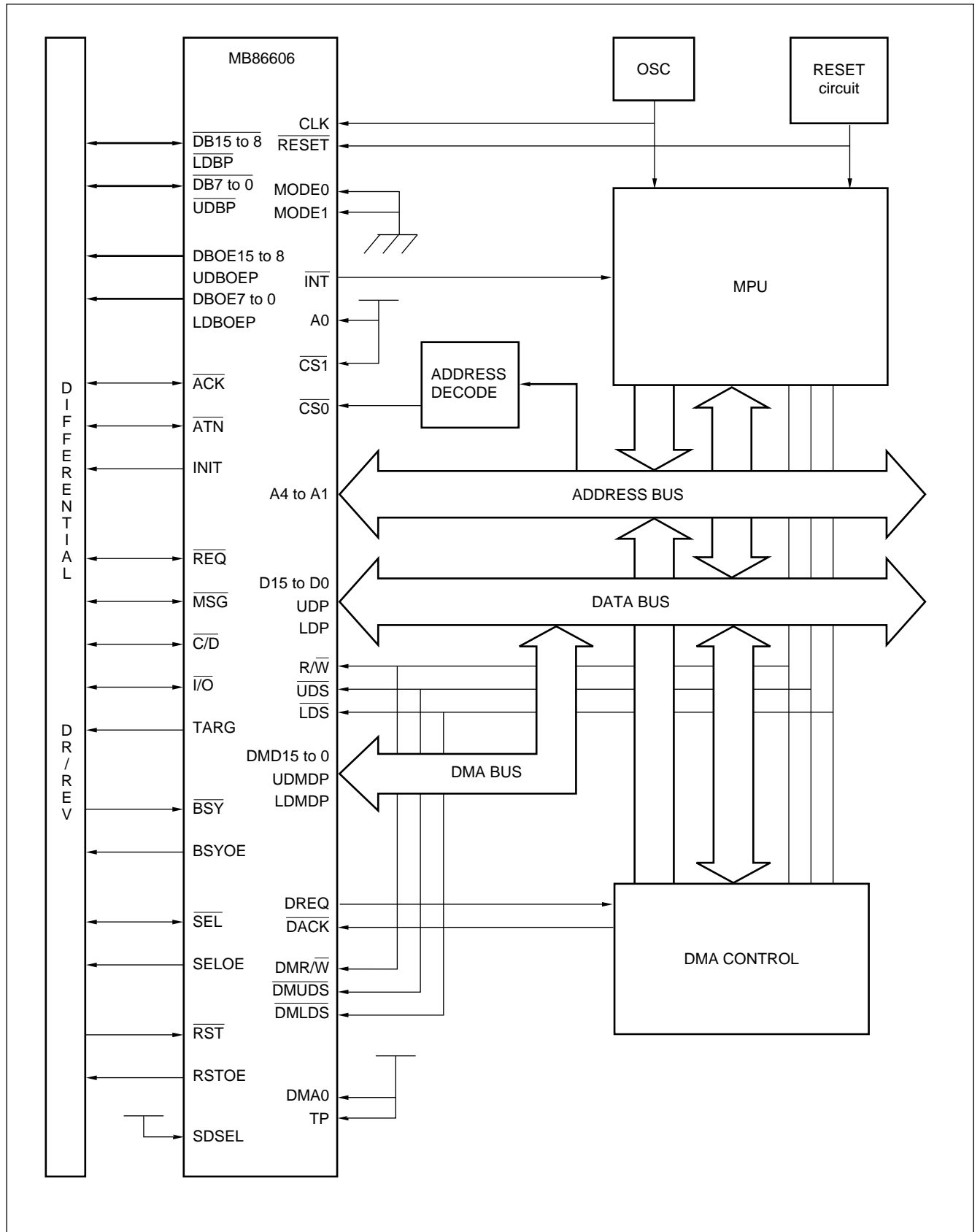

MB86606

5. Example of Connection in Differential Mode (Example of Driver/Receiver Connection)

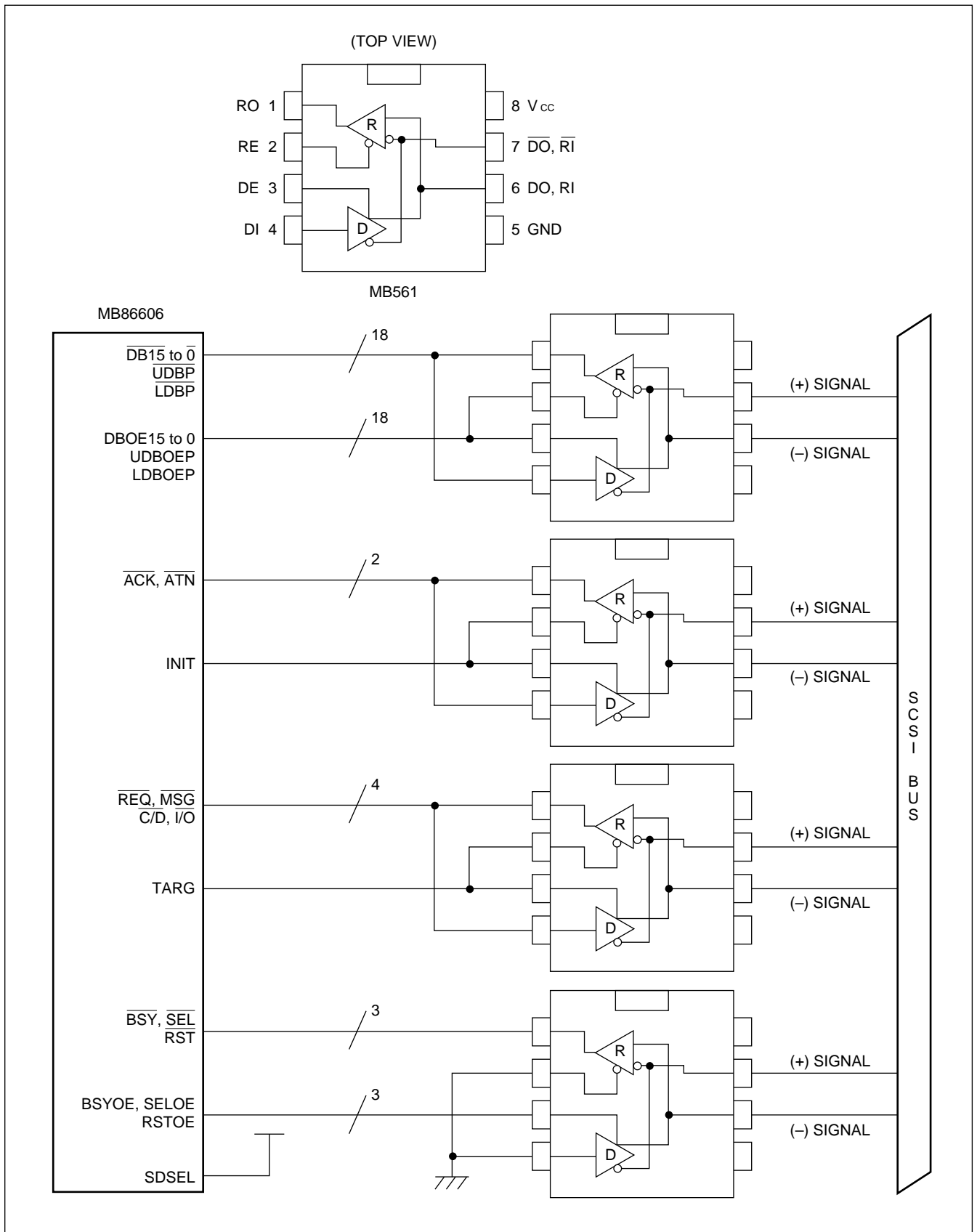

6. Example of Connection in Single-end Mode

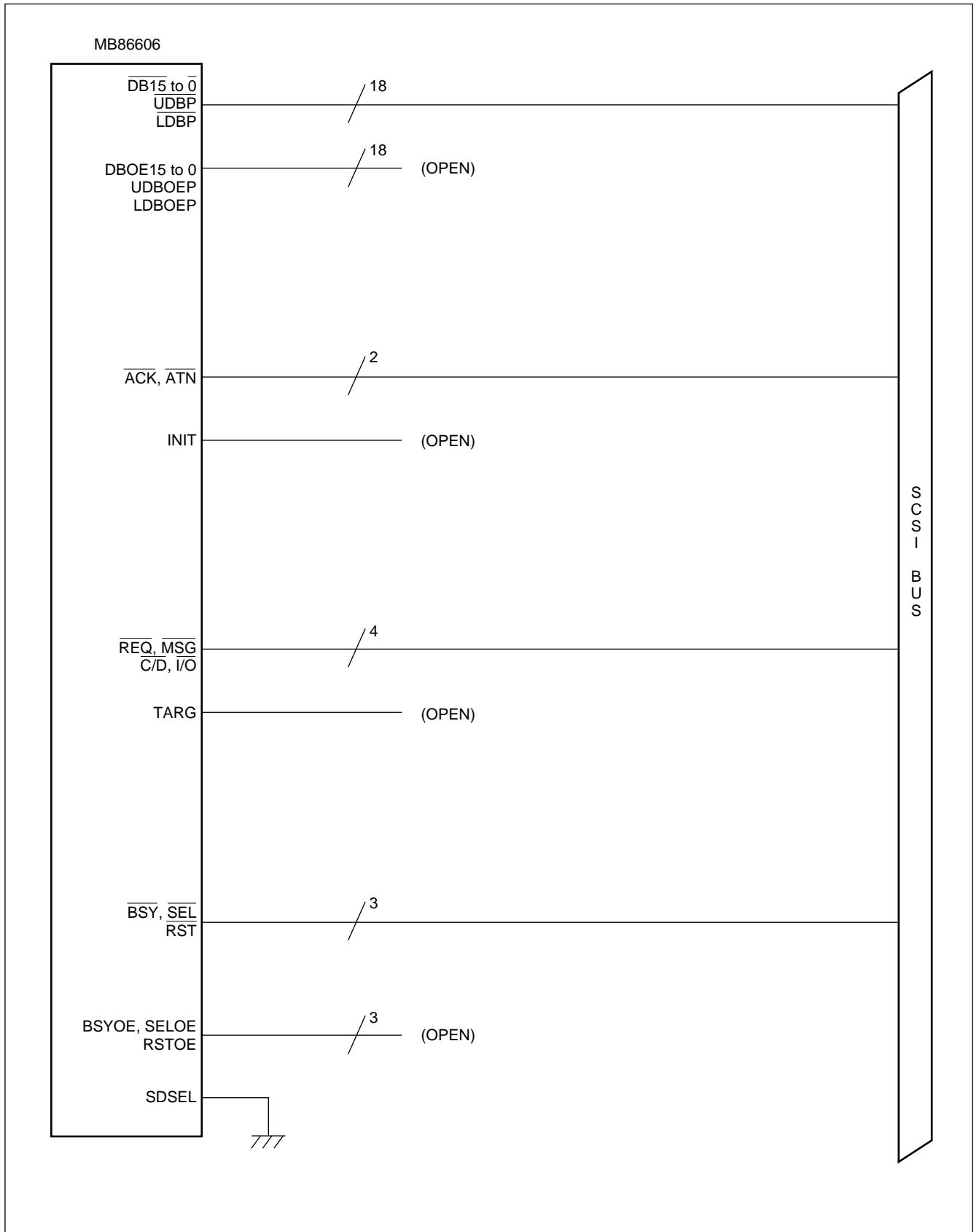

MB86606

■ ORDERING INFORMATION

Part number	Package	Remarks
MB86606PMT	144-pins, Plastic SQFP (FPT-144P-M05)	

■ PACKAGE DIMENSION

144-pin, Plastic SQFP
(FPT-144P-M05)

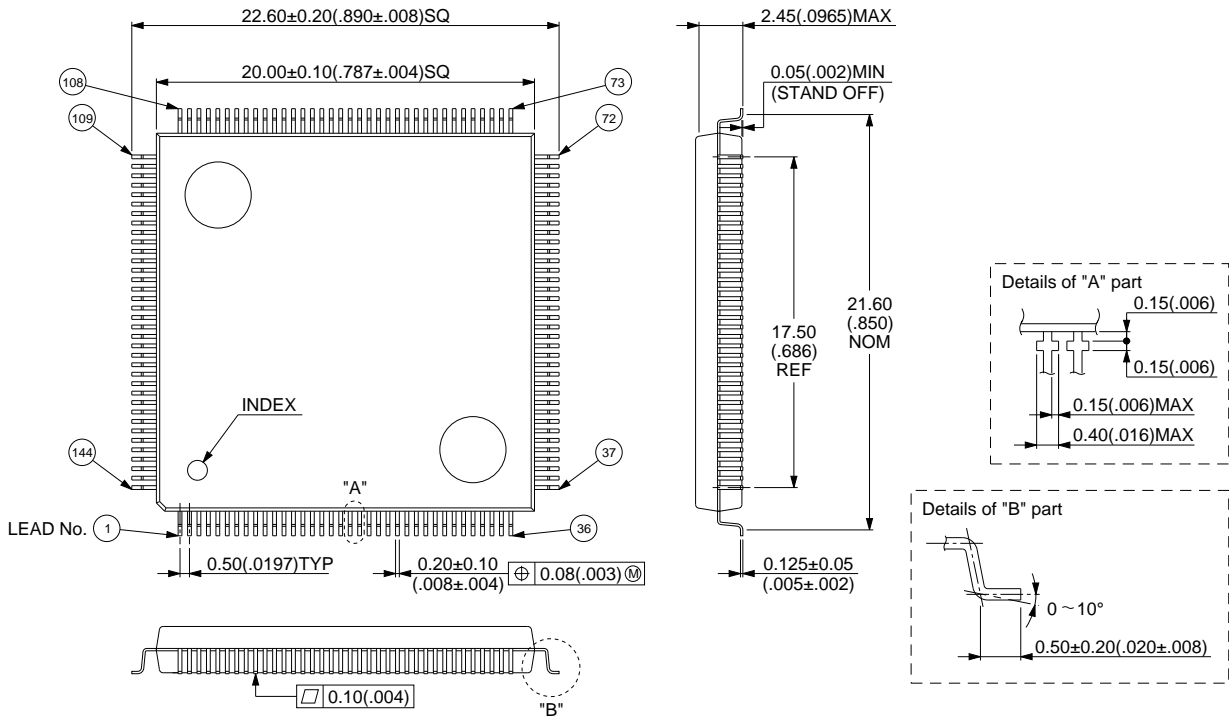

© 1994 FUJITSU LIMITED F144006S-2C-2

Dimensions in mm (inches)

FUJITSU LIMITED

For further information please contact:

Japan

FUJITSU LIMITED
Corporate Global Business Support Division
Electronic Devices
KAWASAKI PLANT, 4-1-1, Kamikodanaka
Nakahara-ku, Kawasaki-shi
Kanagawa 211-88, Japan
Tel: (044) 754-3763
Fax: (044) 754-3329

North and South America

FUJITSU MICROELECTRONICS, INC.
Semiconductor Division
3545 North First Street
San Jose, CA 95134-1804, U.S.A.
Tel: (408) 922-9000
Fax: (408) 432-9044/9045

Europe

FUJITSU MIKROELEKTRONIK GmbH
Am Siebenstein 6-10
63303 Dreieich-Buchsschlag
Germany
Tel: (06103) 690-0
Fax: (06103) 690-122

Asia Pacific

FUJITSU MICROELECTRONICS ASIA PTE. LIMITED
#05-08, 151 Lorong Chuan
New Tech Park
Singapore 556741
Tel: (65) 281-0770
Fax: (65) 281-0220

All Rights Reserved.

The contents of this document are subject to change without notice. Customers are advised to consult with FUJITSU sales representatives before ordering.

The information and circuit diagrams in this document presented as examples of semiconductor device applications, and are not intended to be incorporated in devices for actual use. Also, FUJITSU is unable to assume responsibility for infringement of any patent rights or other rights of third parties arising from the use of this information or circuit diagrams.

FUJITSU semiconductor devices are intended for use in standard applications (computers, office automation and other office equipment, industrial, communications, and measurement equipment, personal or household devices, etc.).

CAUTION:

Customers considering the use of our products in special applications where failure or abnormal operation may directly affect human lives or cause physical injury or property damage, or where extremely high levels of reliability are demanded (such as aerospace systems, atomic energy controls, sea floor repeaters, vehicle operating controls, medical devices for life support, etc.) are requested to consult with FUJITSU sales representatives before such use. The company will not be responsible for damages arising from such use without prior approval.

Any semiconductor devices have inherently a certain rate of failure. You must protect against injury, damage or loss from such failures by incorporating safety design measures into your facility and equipment such as redundancy, fire protection, and prevention of over-current levels and other abnormal operating conditions.

If any products described in this document represent goods or technologies subject to certain restrictions on export under the Foreign Exchange and Foreign Trade Control Law of Japan, the prior authorization by Japanese government should be required for export of those products from Japan.